

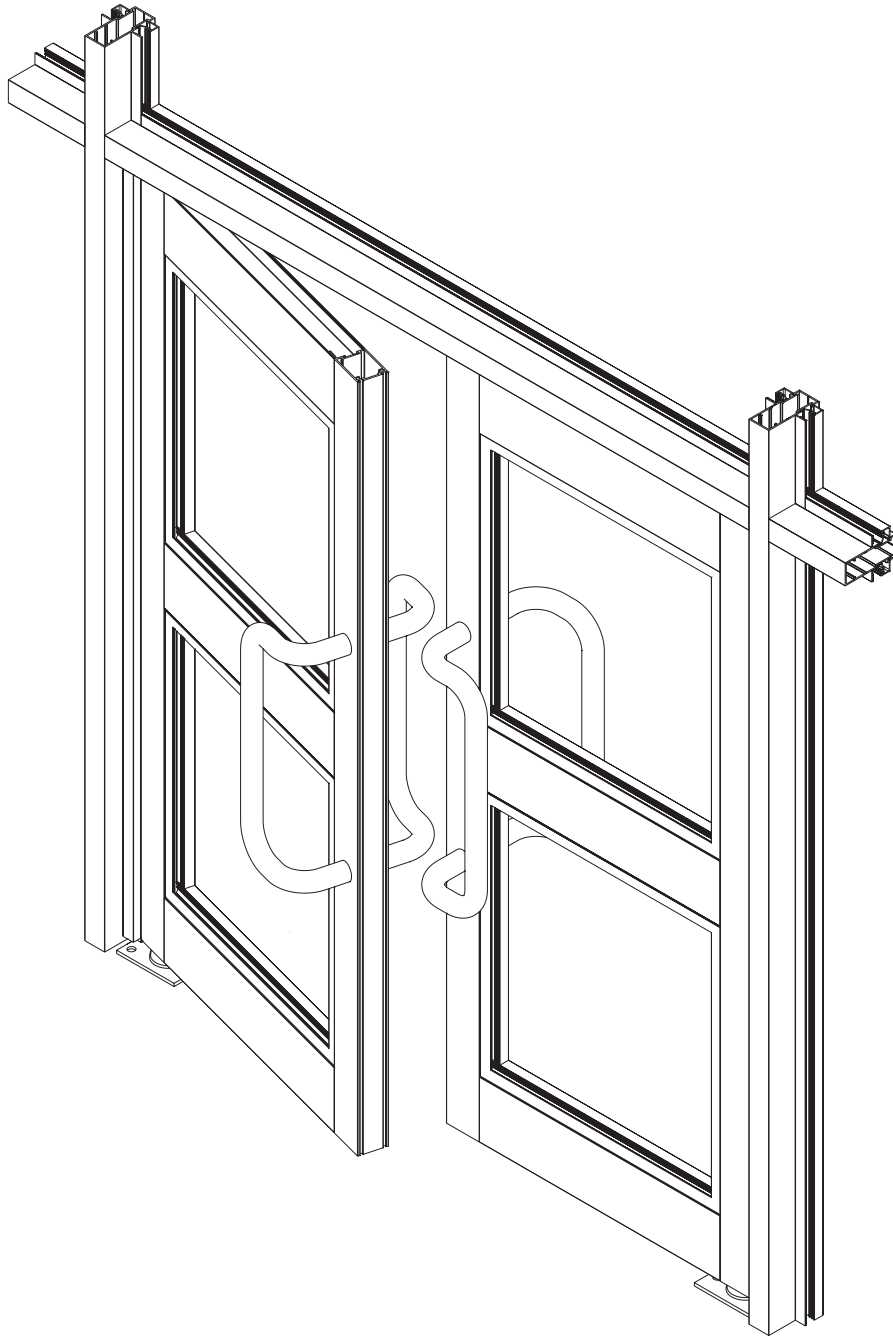

# SHEERFRONT CLIP 15 SYSTEM PIVOT DOORS



## PRODUCT MANUAL

Disclaimer: The right to make alterations is reserved  
© 2010 Sheerline, All Rights Reserved

Revision: 01/010/2010



## LEGAL DISCLAIMER

All information, recommendations or advice contained in this documentation is given in good faith to the best of Sheerline's knowledge and is based on current procedures in effect.

Since the actual use of this documentation by the user is beyond the control of Sheerline, such use is within the exclusive responsibility of the user. Sheerline cannot be held responsible for any loss incurred through incorrect or faulty use of this documentation.

Great care has been taken to ensure that the information provided is correct. Sheerline will accept no responsibility for any errors and/or omissions, which may have inadvertently occurred.

All mechanical joints must be sealed with a Sheerline approved joint sealer.

Laminated glass must not stand in water.

All drawings in the Sheerline Documentation are shown NOT to scale.

Sheerline cannot accept responsibility for the use of standard products since Sheerline does not know where these products are being installed.

The use of anti-magnetic stainless steel screws and pop rivets is recommended to reduce galvanic corrosion in harsh environments.

The hardware recommended in this documentation is suitable for use in most atmospheric environments. When hardware is used in severe coastal environments the manufacturer of the hardware must be consulted.

Fixing lugs on frames must be positioned as per the user manual and used in accordance to the AAAMSA specifications. When profiles are screwed together the screw centers must also be according to the user manual.

All glass used within Sheerline products must comply with SAGGA regulations.

**By continuing to use this documentation you acknowledge that you understand and accept the legal disclaimer.**

# SHEERFRONT CLIP 15 SYSTEM PROFILE IDENTIFICATION

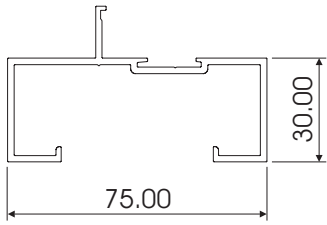

CLIP44 26C JAMB  
OPEN BACK  
CL03A

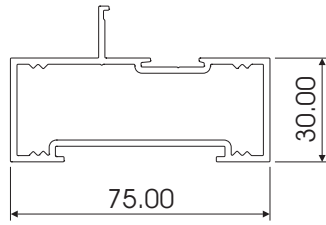

CLIP44 26B  
RECESSED BACK  
CL02A

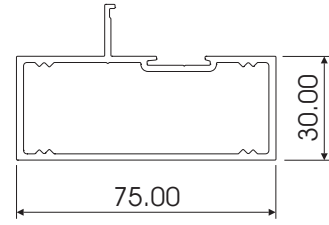

CLIP44 26E  
FLAT BACK  
CL49A

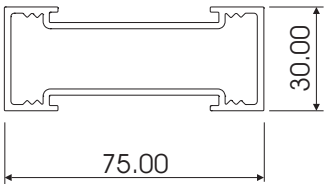

CLIP44 26D  
RECESSED BACK  
CL47A

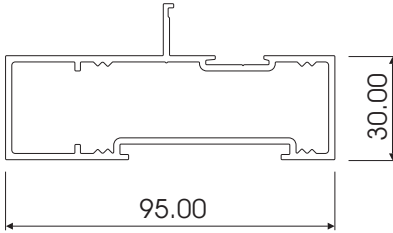

CLIP44 95B  
RECESSED BACK  
CL200

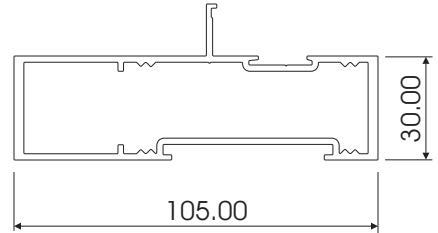

CLIP44 105B  
RECESSED BACK  
CL201

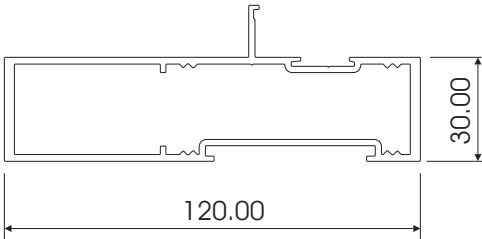

CLIP44 120B  
RECESSED BACK  
CL202

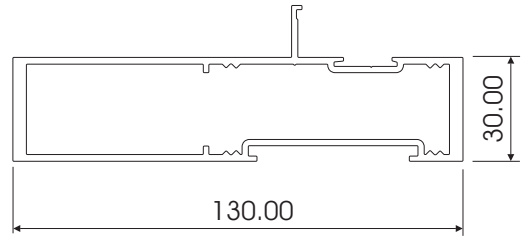

CLIP44 130B  
RECESSED BACK  
CL217

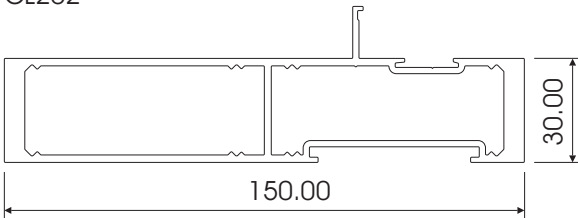

CLIP44 150B  
RECESSED BACK  
CL203

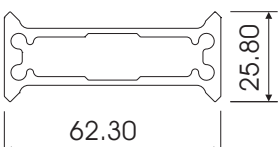

CLIP44 BOX SPIGOT  
4 X S/PORT  
W55456

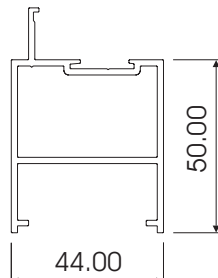

CLIP44 R7 HEAD/  
SILL RAIL 50mm  
CL22A

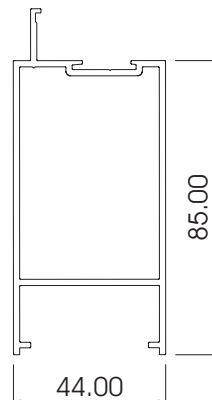

CLIP44 R4 HEAD/  
SILL RAIL 85mm  
CL17A

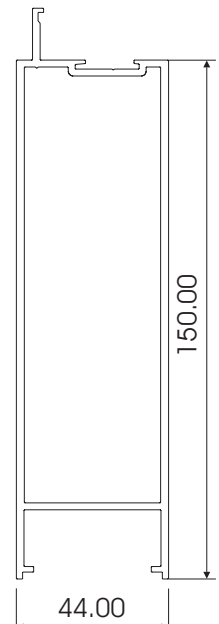

CLIP44 R6 SILL  
RAIL 150mm  
CL56A

# SHEERFRONT CLIP 15 SYSTEM PROFILE IDENTIFICATION

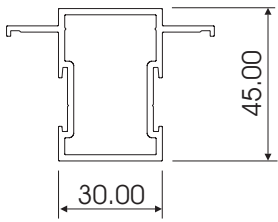

CLIP44 GLAZING BAR  
CL72A

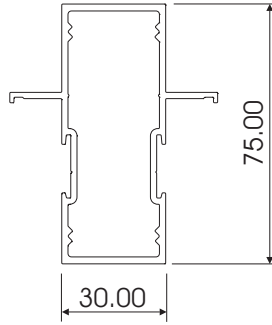

CLIP44 26 MULLION  
CL01A

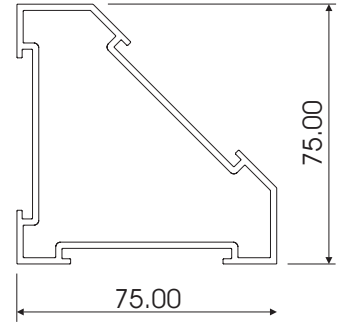

CLIP44 CORNER MULLION  
CL08A

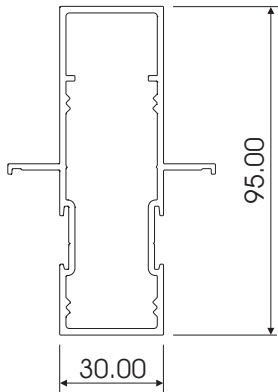

CLIP44 MULLION W95  
CL215

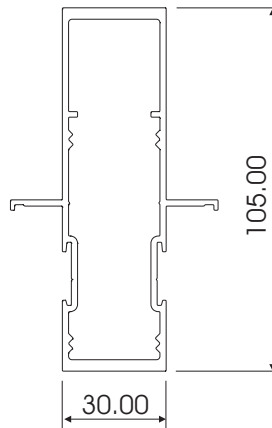

CLIP44 MULLION W105  
CL216

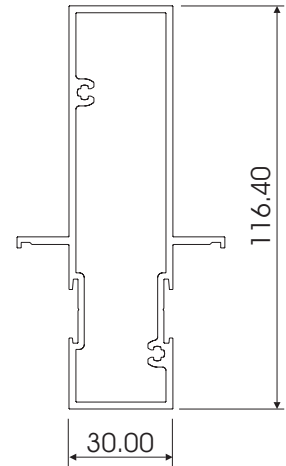

CLIP44 MULLION 116.4mm  
CL219

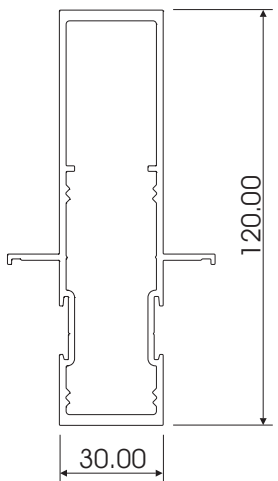

CLIP44 MULLION W120  
CL06A

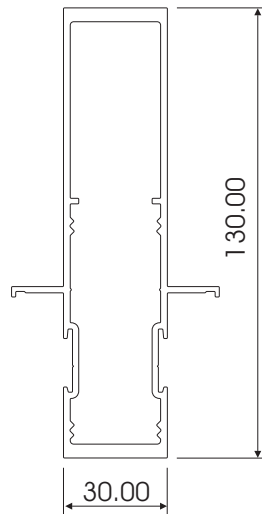

CLIP44 MULLION W130  
CL226

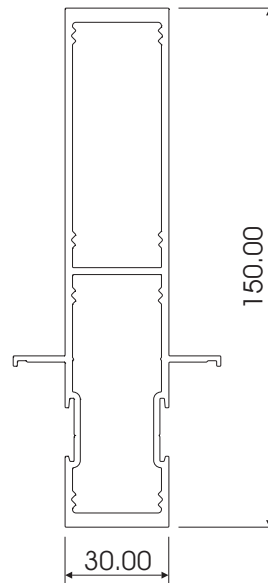

CLIP44 W150 MULLION  
CL07A

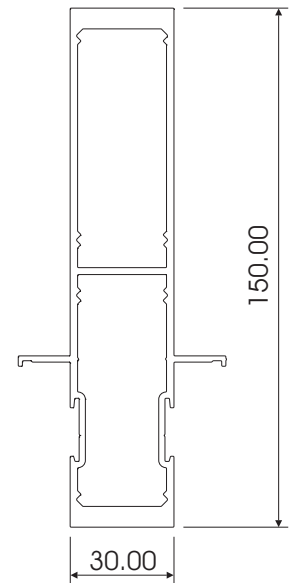

CLIP44 150mm MULLION  
HEAVY DUTY  
CL204

# SHEERFRONT CLIP 15 SYSTEM PROFILE IDENTIFICATION

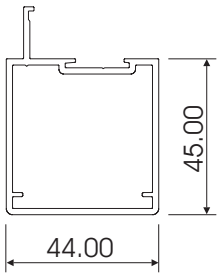

CLIP44 R1  
DOOR JAMB  
CL15A

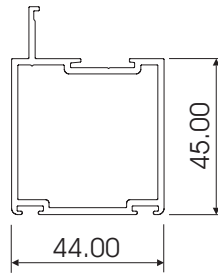

CLIP44 R3 SPECIAL  
DOOR JAMB  
CL16A

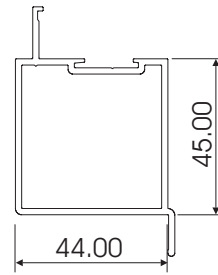

CLIP44 R12 DOUBLE  
DOOR JAMB  
CL214

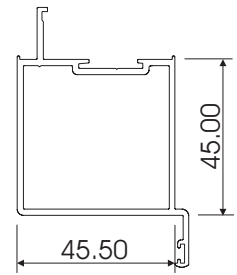

CLIP44 R12 SPECIAL  
CL42A

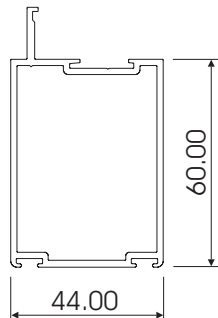

CLIP44 R11W  
D/STILE 60mm W/PILE  
CL221

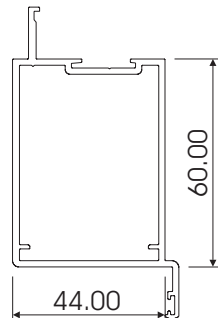

CLIP44 R11SP  
D/STILE 60mm  
CL227

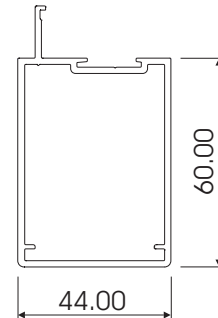

CLIP44 R11  
DOOR JAMB  
CL218

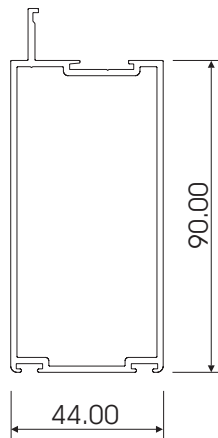

CLIP44 R9W  
D/STILE 90mm W/PILE  
CL51A

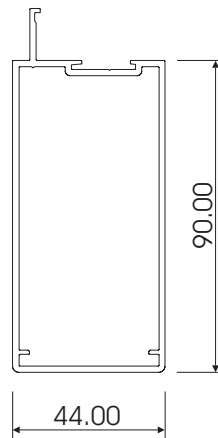

CLIP44 R9  
D/STILE 90mm  
CL52A

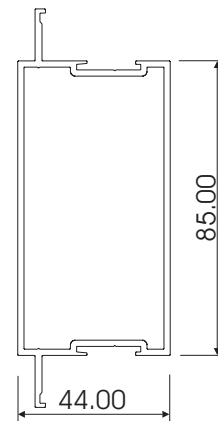

CLIP44 R4-SPECIAL  
MID RAIL 85mm  
CL18A

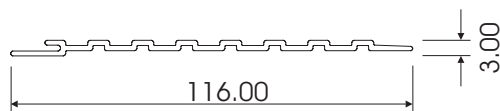

CLIP44 R19 SPECIAL CLADDING  
W27934

# SHEERFRONT CLIP 15 SYSTEM ALTERNATE WOOLPILE PROFILES

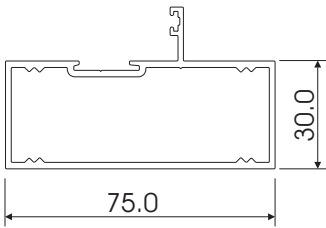

CLIP44 FLAT  
BACK WOOLPILE  
CL49GW

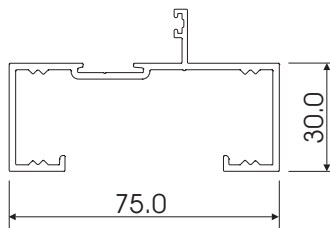

CLIP44 JAMB  
OPEN BACK WOOLPILE  
CL03GW

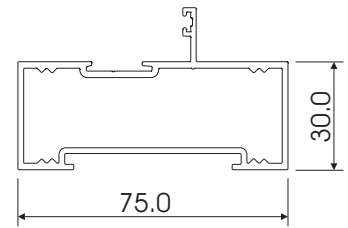

CLIP 44 RECESSED  
BACK WOOLPILE  
CL02GW

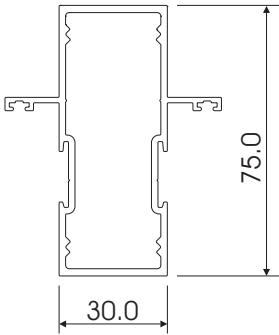

CLIP44 MULLION  
WOOLPILE  
CL01GW

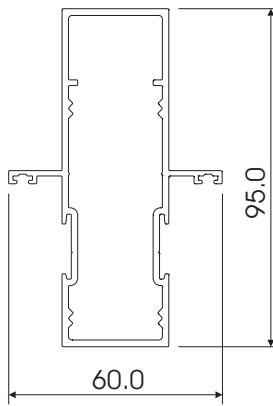

CLIP44 W95 MULLION  
WOOLPILE  
W56015

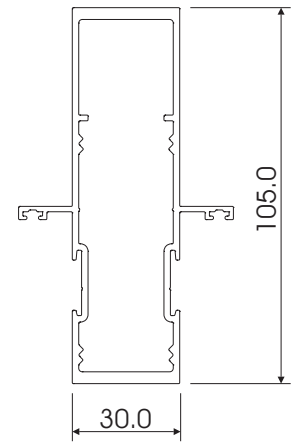

CLIP44 W105 MULLION  
WOOLPILE  
W56014

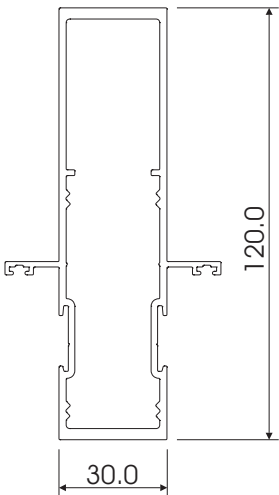

CLIP44 W150 MULLION  
WOOLPILE  
CL06GW

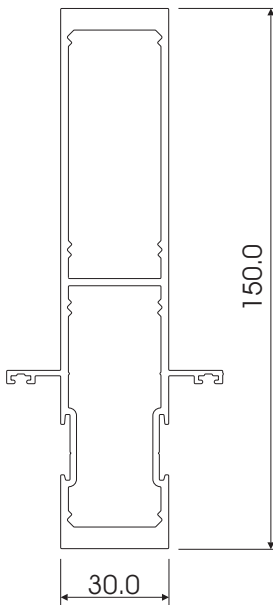

CLIP44 150mm MULLION  
WOOLPILE HEAVY DUTY  
W56012

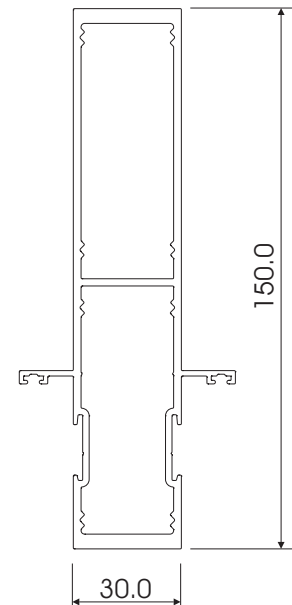

CLIP44 W150 MULLION  
WOOLPILE  
CL07GW

# SHEERFRONT CLIP 15 SYSTEM PROFILE IDENTIFICATION

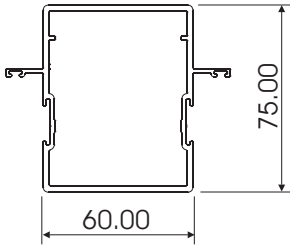

MID-TRANSOME RAIL  
60MM WP  
CL103G

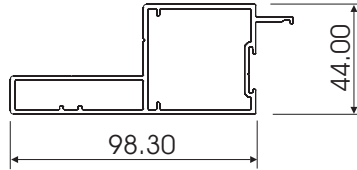

MAGLOCK DOUBLE  
DOOR STILE OPENING DOOR  
CL95

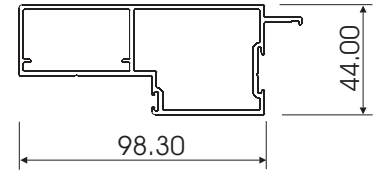

MAGLOCK DOUBLE  
DOOR STILE FIXED DOOR  
CL94

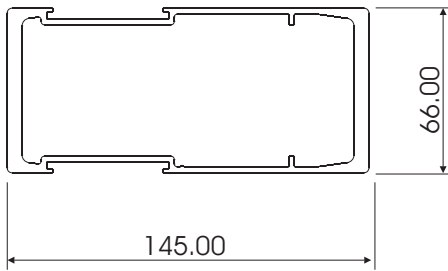

MULLION-TRANSOM  
145x66 RECESSED  
CL76A

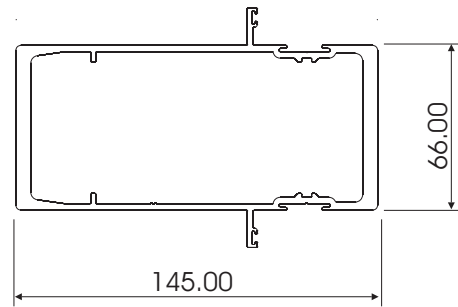

MULLION-TRANSOM  
145x66 DOUBLE LIP WP  
CL76G

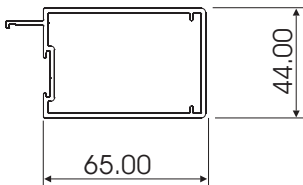

DOOR STILE 65MM  
CL28

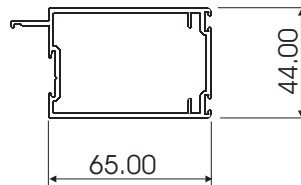

DOOR STILE 65MM  
WOOLPILE  
CL65L

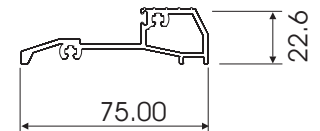

THRESHOLD WITH  
SEAL  
CL69

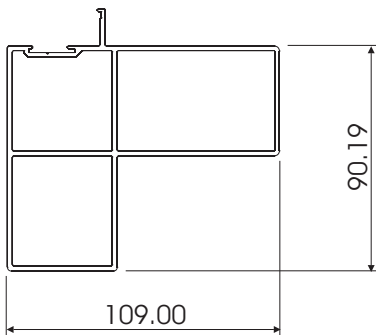

MAG LOCK  
CL73

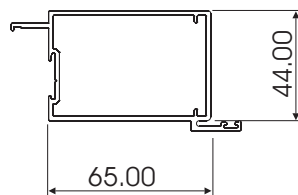

DOOR STILE 65MM  
CL61L

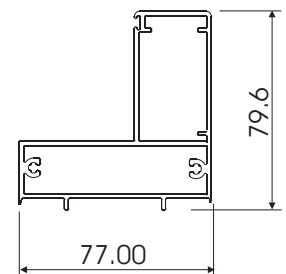

LOCK STILE  
CL64

# SHEERFRONT CLIP 15 SYSTEM PROFILE IDENTIFICATION

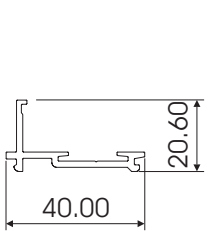

CLIP44 R4 FILLER  
ADAPTOR  
CL19A

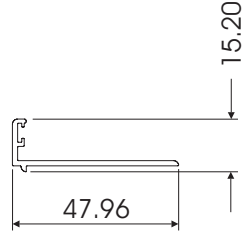

CLIP44 ASTRAGAL  
WITH WOOLPILE  
CL206

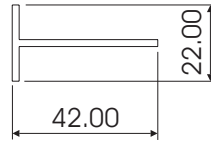

CLIP44 SLIDING DOOR  
STOP ASTRAGAL  
CL35A

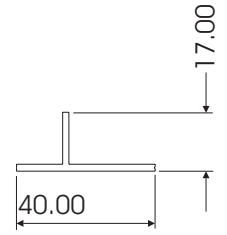

CLIP44 R4 SILL  
END FILLER  
CL20A

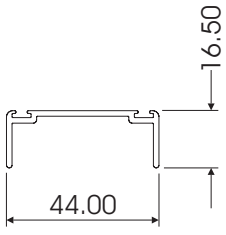

CLIP44 PIVOT DOOR  
HEAD ADAPTOR  
CL44A

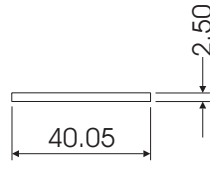

CLIP44 40mm  
COVER PLATE  
FB24

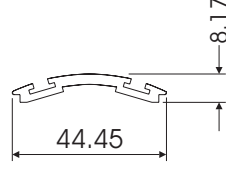

CLIP44 SILL ADAPTOR  
CL104

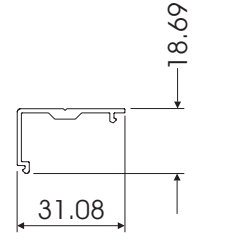

CLIP44 DOOR  
ADAPTOR FOR W95  
CL211

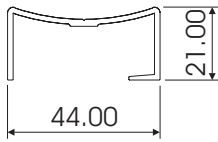

CLIP44 DOOR END  
STYLE FOR PIVOT  
CL24A

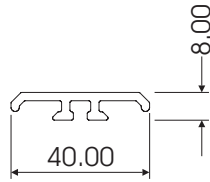

COLONIAL BAR  
CL208

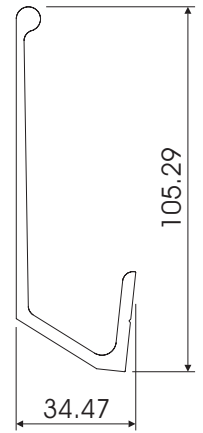

CLIP44 UNIVERSAL  
DOOR HANDLE  
CL37

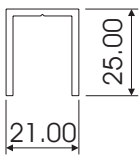

CLIP44 CHANNEL  
SPIGOT  
W26152



CLIP44 COMPENSATING  
CHANNEL  
CH16

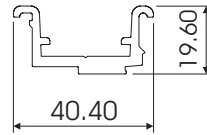

CLIP44 SPIGOT  
CL25A

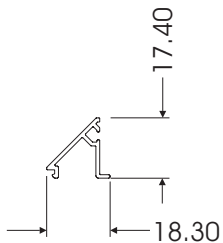

CLIP44 ANGLED  
GLAZING BEAD  
CL13

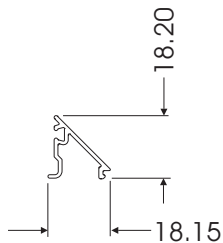

NEW CLIP44 ANGLED  
GLAZING BEAD  
CL13A

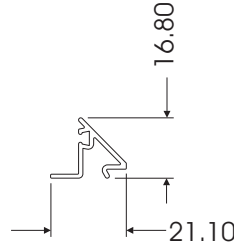

CLIP44 ANGLED  
GLAZING BEAD  
CL225

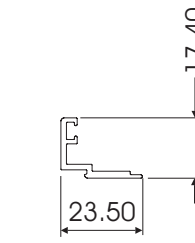

CLIP44 DOUBLE  
GLAZING BEAD  
CL66A

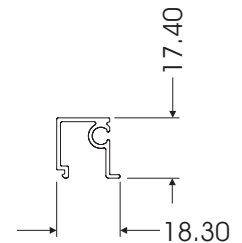

CLIP44 SQUARE  
GLAZING BEAD  
CL14A

# SHEERFRONT CLIP 15 SYSTEM PIVOT DOOR INSERT HARDWARE IDENTIFICATION

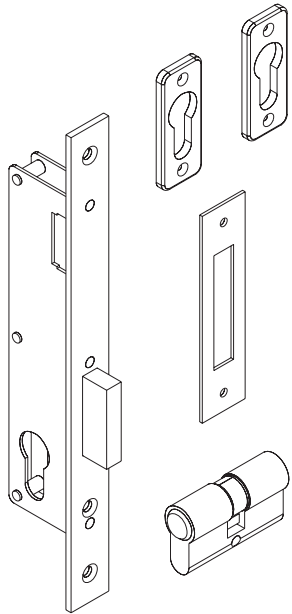

DEAD LOCK 25mm  
CL44640/25

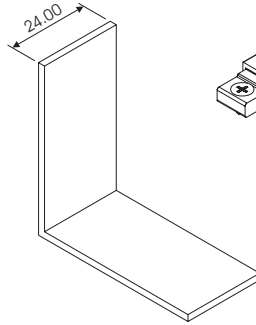

EQUAL ANGLE 50.0 x 50.0 x 2.0  
W20435

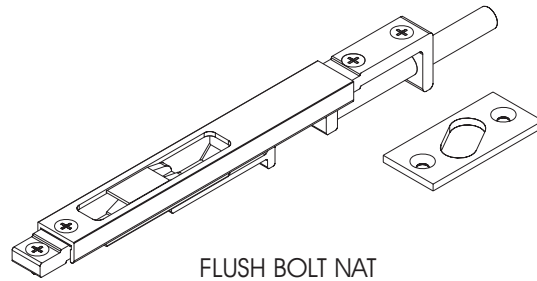

FLUSH BOLT NAT  
ALUFAB - 150x19mm  
SHW04

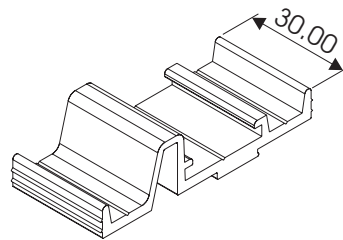

FRAME SPIGOT  
CL39A

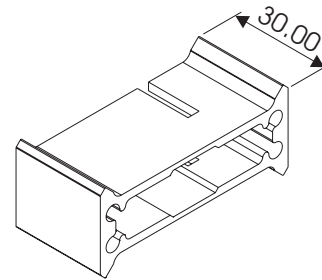

BOX SPIGOT 4 X S/PORT  
CL40W

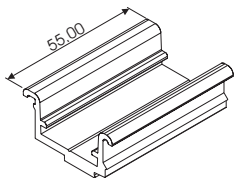

SPIGOT  
CL25A

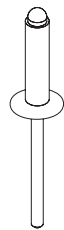
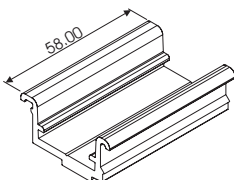

4x10 C/SUNK  
RIVET  
CSKR410



POP RIVET  
4.8x12mm  
CSKR4812



8x40 P/HEAD POSI  
S/S SCREW  
SC0840P

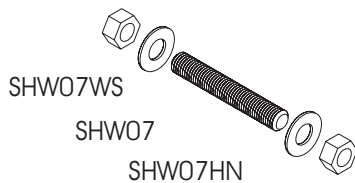

SHW07WS  
SHW07  
SHW07HN

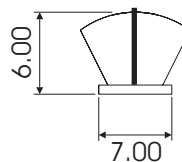

FINPILE  
FP69600FG

SHEERFRONT CLIP 15 SYSTEM  
PIVOT DOOR INSERT  
HARDWARE IDENTIFICATION

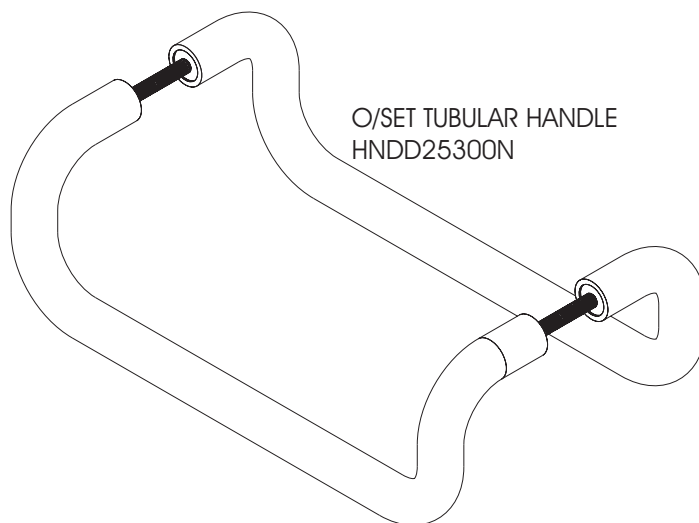

TOP CENTRE STRAP + PIVOT

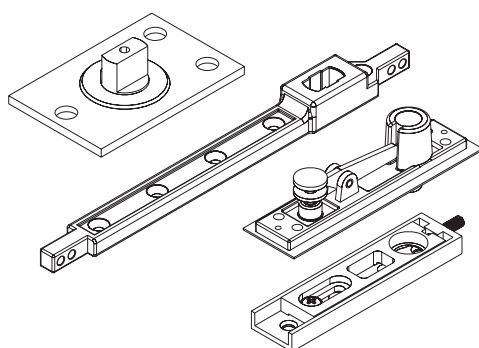

SHEERFRONT CLIP 15 SYSTEM  
PIVOT DOOR LEAF  
SIZE LIMITATION GUIDE

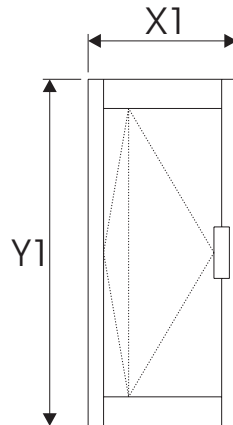

WHEN USING 45mm DOOR JAMB (EG. CL15A - R1 DOOR JAMB)

MAXIMUM DOOR LEAF WIDTH:  $X1 = 1000\text{mm}$   
MAXIMUM DOOR LEAF HEIGHT:  $Y1 = 2200\text{mm}$

WHEN USING 60mm DOOR JAMB (EG. CL221 - R11W DOOR JAMB)

MAXIMUM DOOR LEAF WIDTH:  $X1 = 1100\text{mm}$   
MAXIMUM DOOR LEAF HEIGHT:  $Y1 = 2400\text{mm}$

WHEN USING 90mm DOOR JAMB (EG. CL51A - R9W DOOR JAMB)

MAXIMUM DOOR LEAF WIDTH:  $X1 = 1200\text{mm}$   
MAXIMUM DOOR LEAF HEIGHT:  $Y1 = 2600\text{mm}$

# SHEERFRONT CLIP 15 SYSTEM PIVOT DOOR TYPICAL CONFIGURATIONS

SINGLE PIVOT DOOR

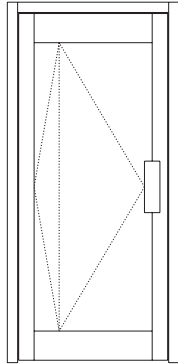

DOUBLE PIVOT DOOR

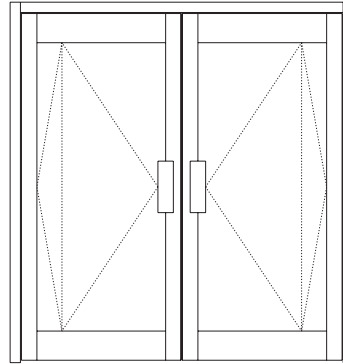

SINGLE PIVOT DOOR  
WITH MIDRAIL

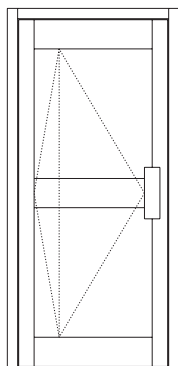

DOUBLE PIVOT DOOR  
WITH MIDRAIL

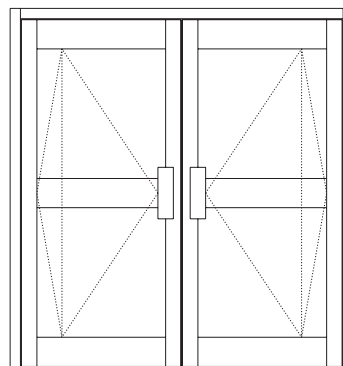

# SHEERFRONT CLIP 15 SYSTEM PIVOT DOOR FIXING DETAILS

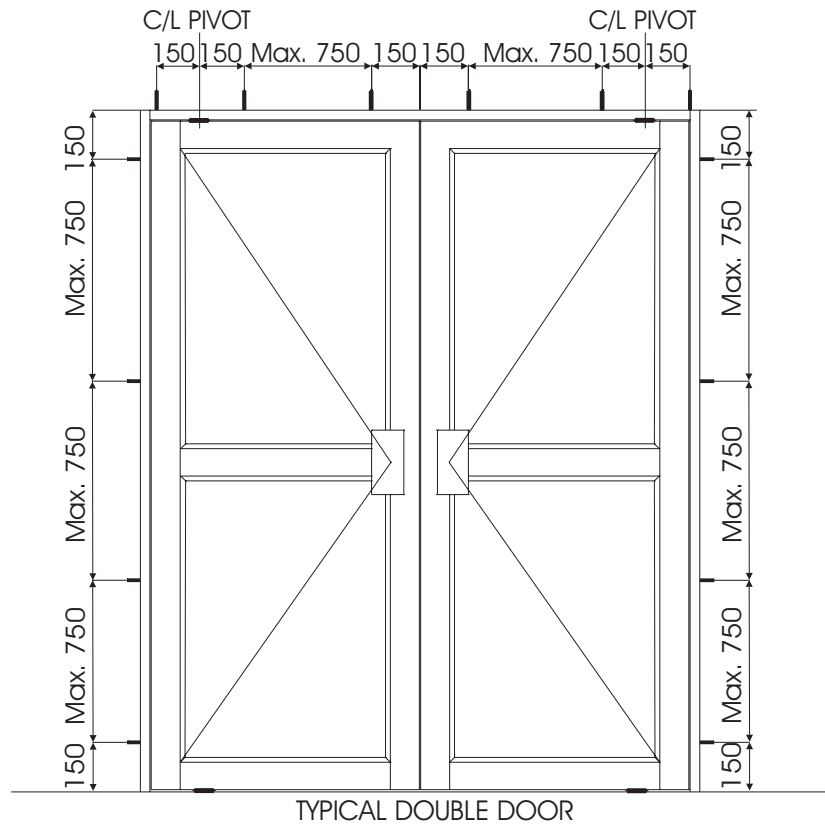
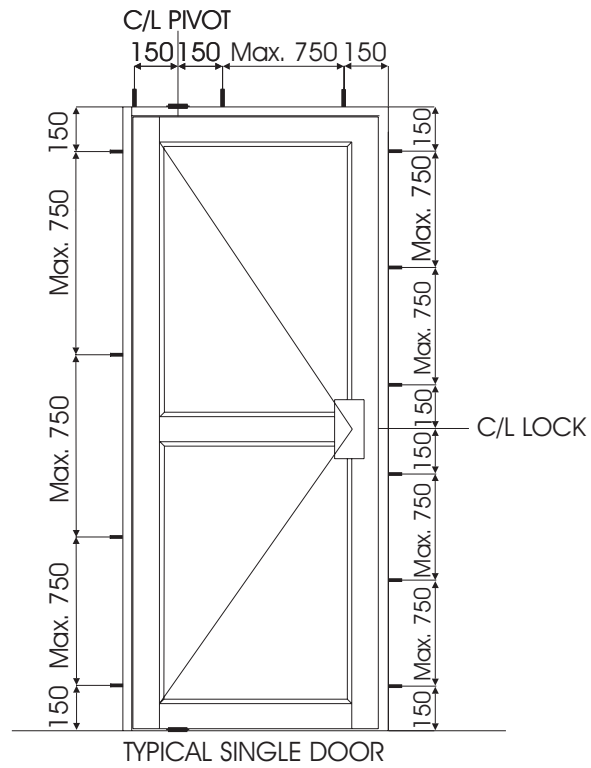

# SHEERFRONT CLIP 15 SYSTEM SINGLE PIVOT DOOR CROSS SECTIONAL DETAIL

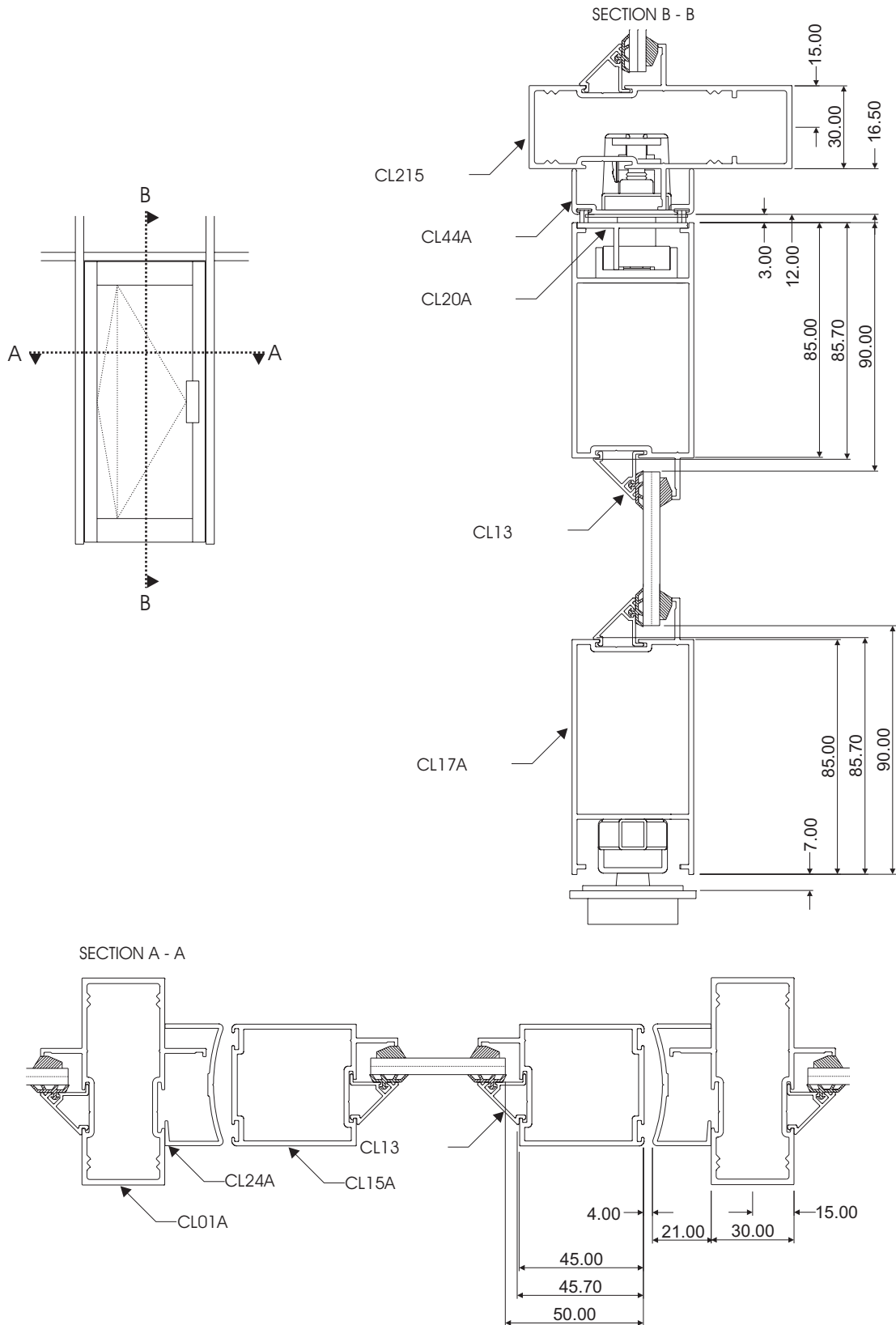

Disclaimer: The right to make alterations is reserved  
© 2010 Sheerline, All Rights Reserved

# SHEERFRONT CLIP 15 SYSTEM SINGLE PIVOT DOOR WITH MIDRAIL CROSS SECTIONAL DETAIL

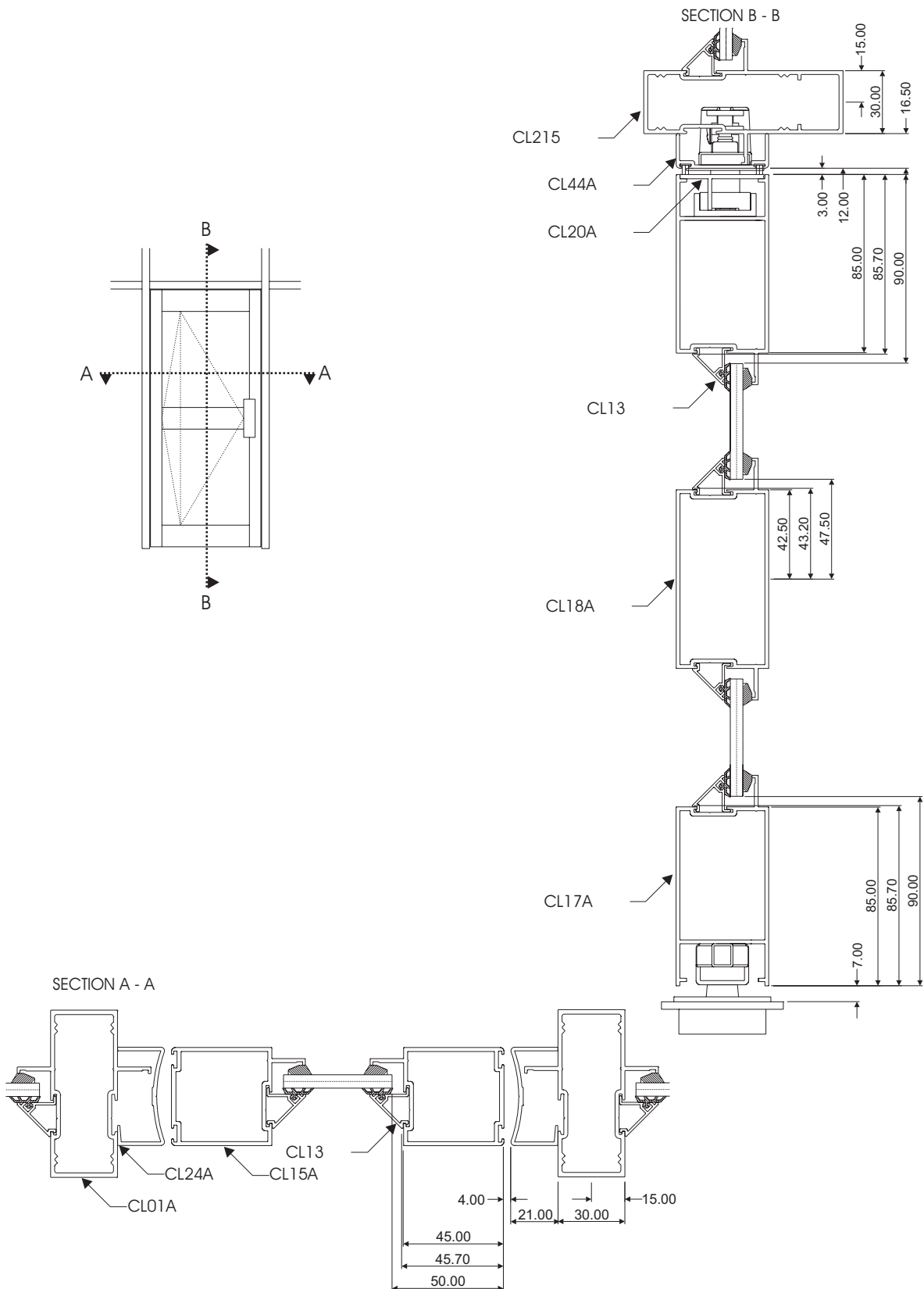

Disclaimer: The right to make alterations is reserved  
© 2010 Sheerline, All Rights Reserved

# SHEERFRONT CLIP 15 SYSTEM DOUBLE PIVOT DOOR CROSS SECTIONAL DETAIL

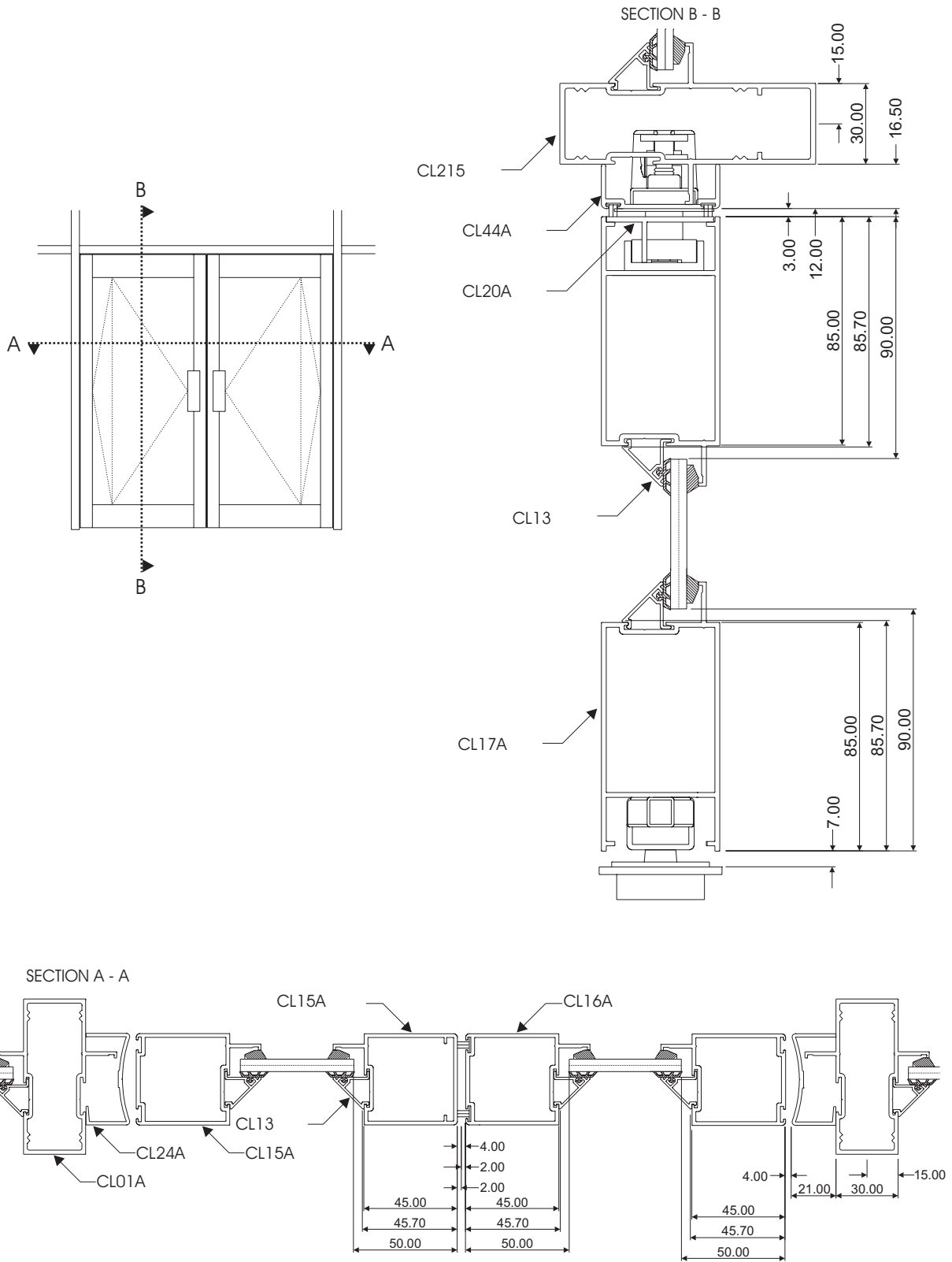

# SHEERFRONT CLIP 15 SYSTEM DOUBLE PIVOT DOOR WITH MIDRAIL CROSS SECTIONAL DETAIL

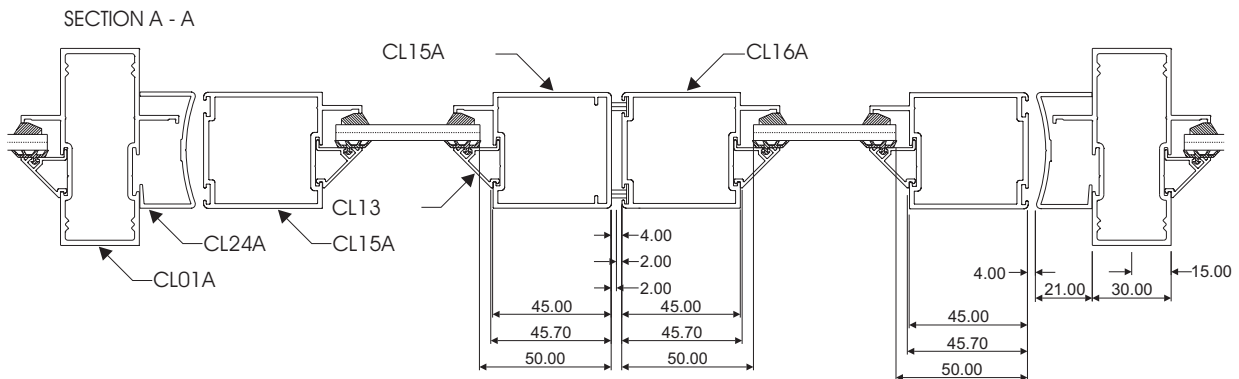
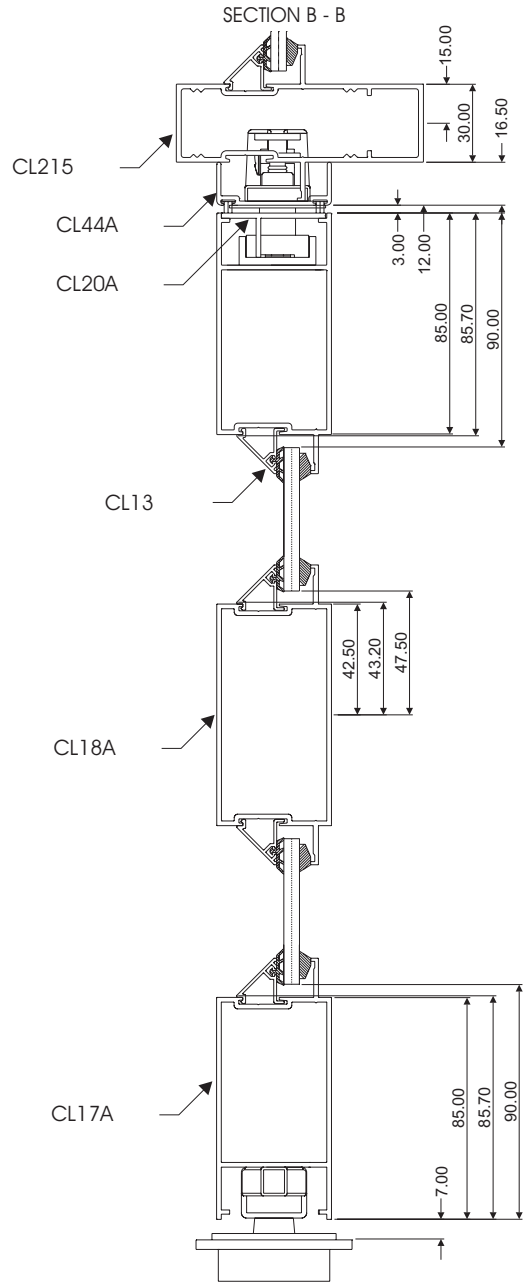
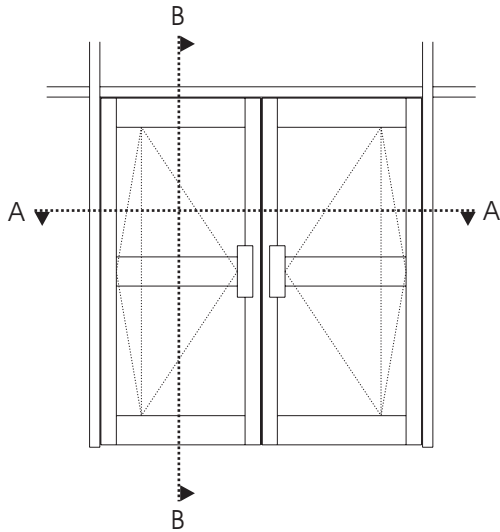

Disclaimer: The right to make alterations is reserved  
© 2010 Sheerline, All Rights Reserved

# SHEERFRONT CLIP 15 SYSTEM PIVOT DOOR COMPONENT ASSEMBLY DETAIL

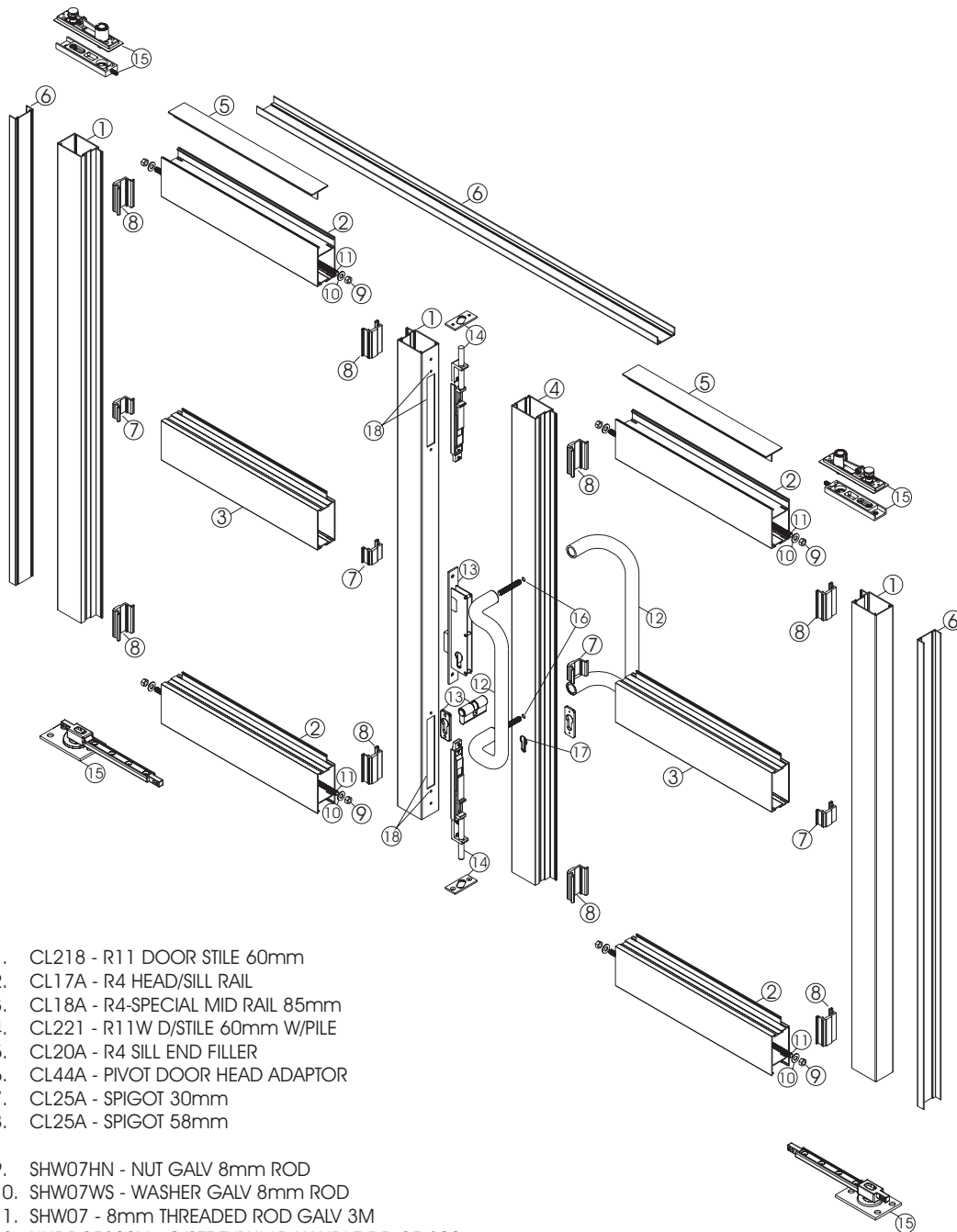

1. CL218 - R11 DOOR STILE 60mm
2. CL17A - R4 HEAD/SILL RAIL
3. CL18A - R4-SPECIAL MID RAIL 85mm
4. CL221 - R11W D/STILE 60mm W/PILE
5. CL20A - R4 SILL END FILLER
6. CL44A - PIVOT DOOR HEAD ADAPTOR
7. CL25A - SPIGOT 30mm
8. CL25A - SPIGOT 58mm
9. SHW07HN - NUT GALV 8mm ROD
10. SHW07WS - WASHER GALV 8mm ROD
11. SHW07 - 8mm THREADED ROD GALV 3M
12. HNDD25300N - O/SET TUBULAR HANDLE-DD 25 300
13. CL44640/25 - DEAD LOCK 25mm
14. SHW04 - FLUSH BOLT NAT ALUFAB 150x19mm
15. PIVOT SET (PSAT)
16. HANDLE MACHINING DETAIL SEE PAGE 25
17. LOCK MACHINING DETAIL SEE PAGE 26
18. FLUSHBOLT MACHINING DETAIL SEE PAGE 27

# SHEERFRONT CLIP 15 SYSTEM PIVOT DOOR SILL MACHINING DETAIL TO SUIT ALL SILL COMBINATIONS



NOTE:  
FOR SILL COMBINATIONS PLEASE  
REFER TO PAGE 17 OF THIS MANUAL

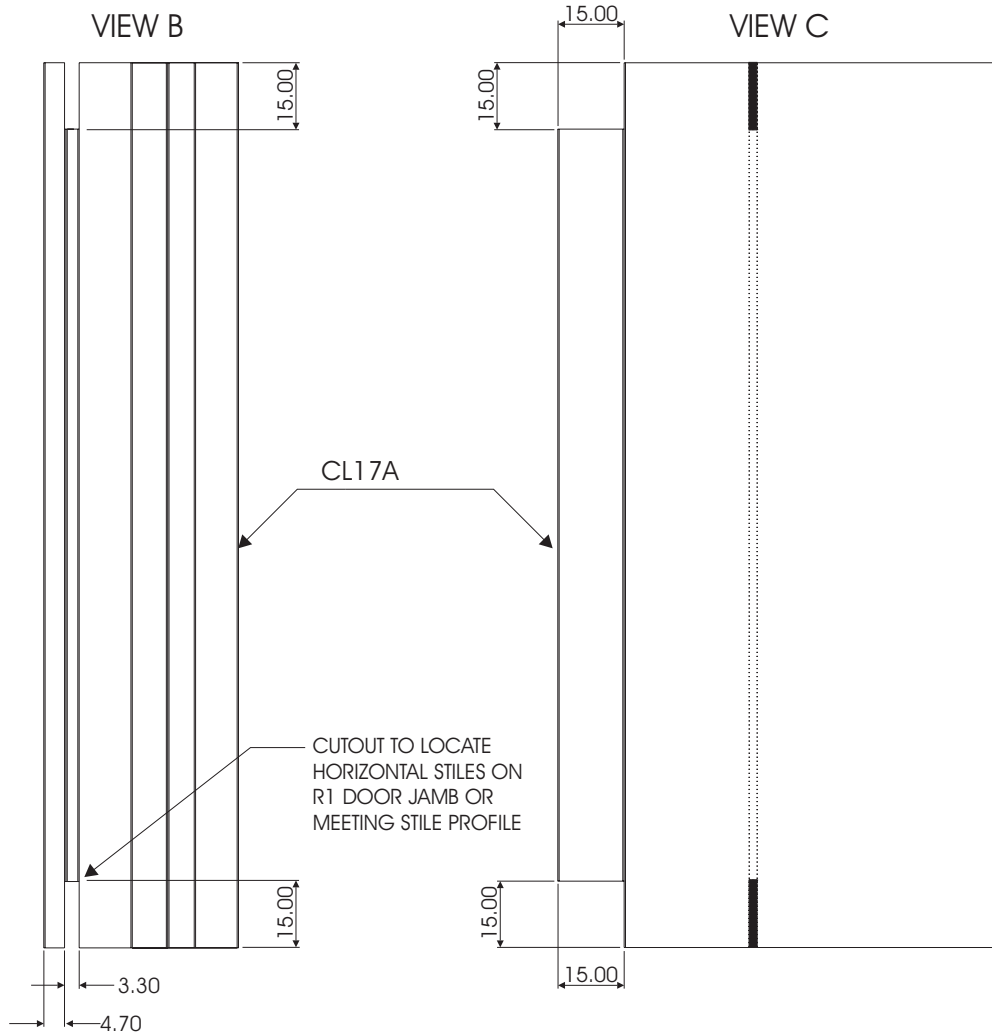
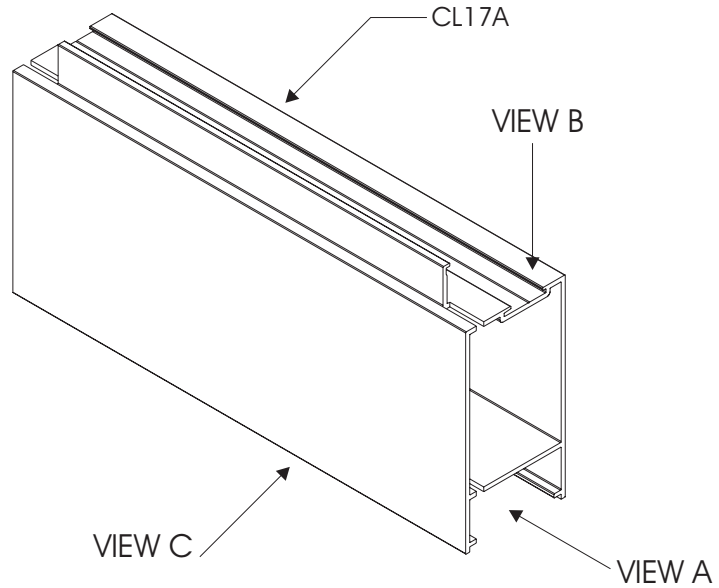
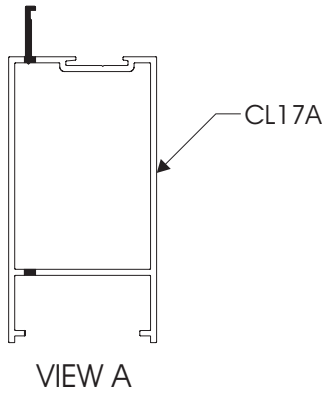

# SHEERFRONT CLIP 15 SYSTEM SILL COMBINATIONS

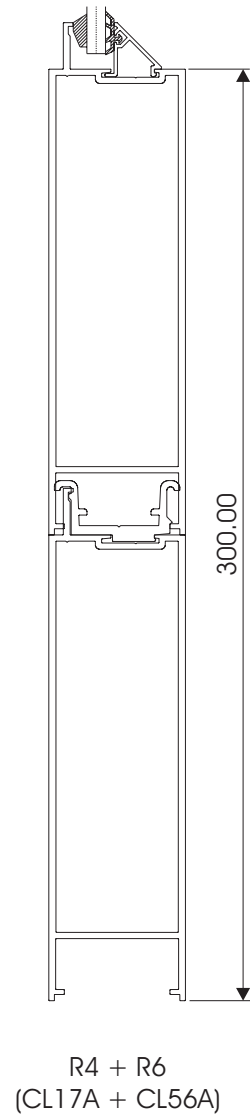
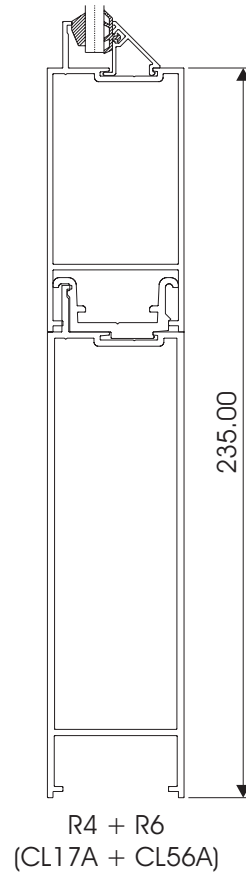
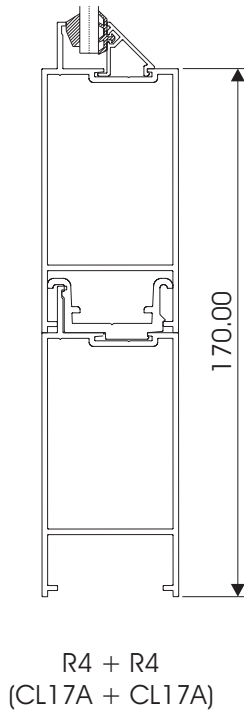
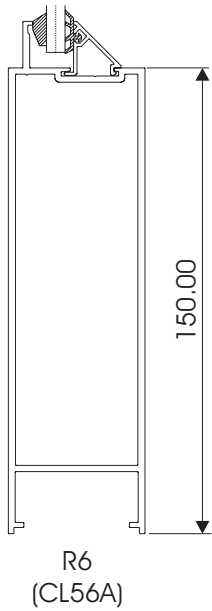
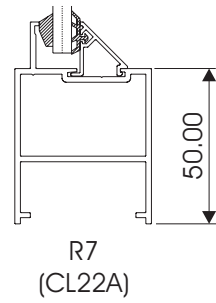
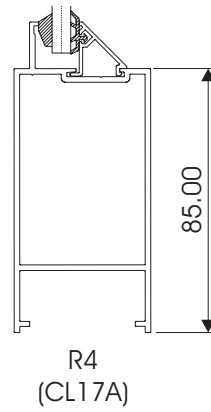
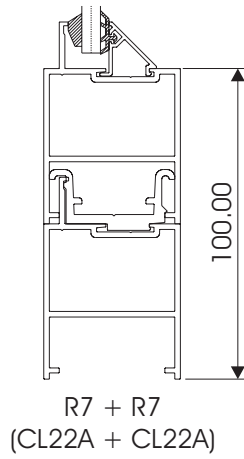
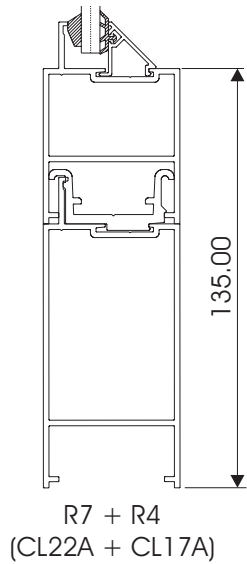

SHEERFRONT CLIP 15 SYSTEM  
PIVOT DOOR SILL  
FLOOR LEVEL DETAIL

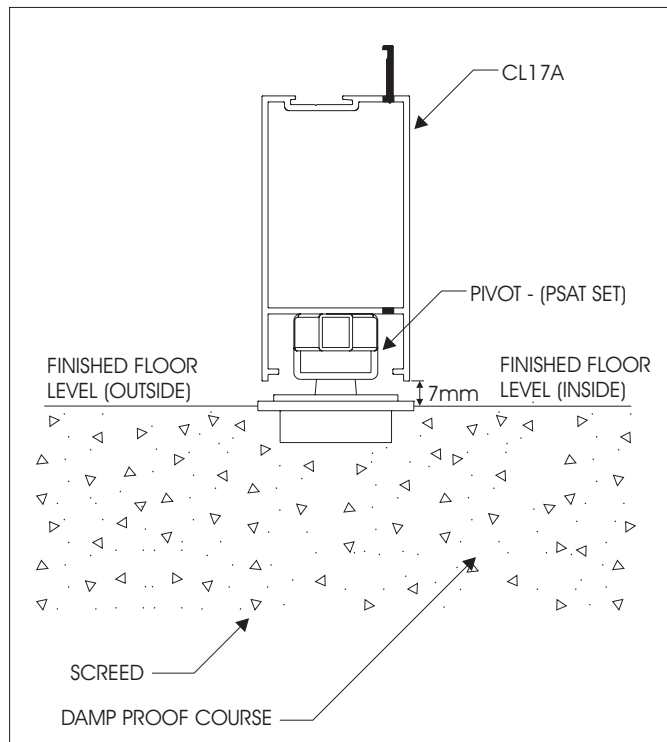
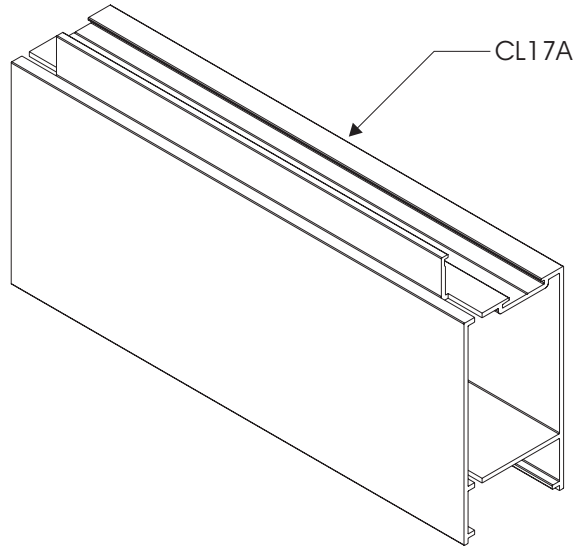

# SHEERFRONT CLIP 15 SYSTEM PIVOT DOOR MIDRAIL MACHINING DETAIL TO SUIT ALL COMBINATIONS

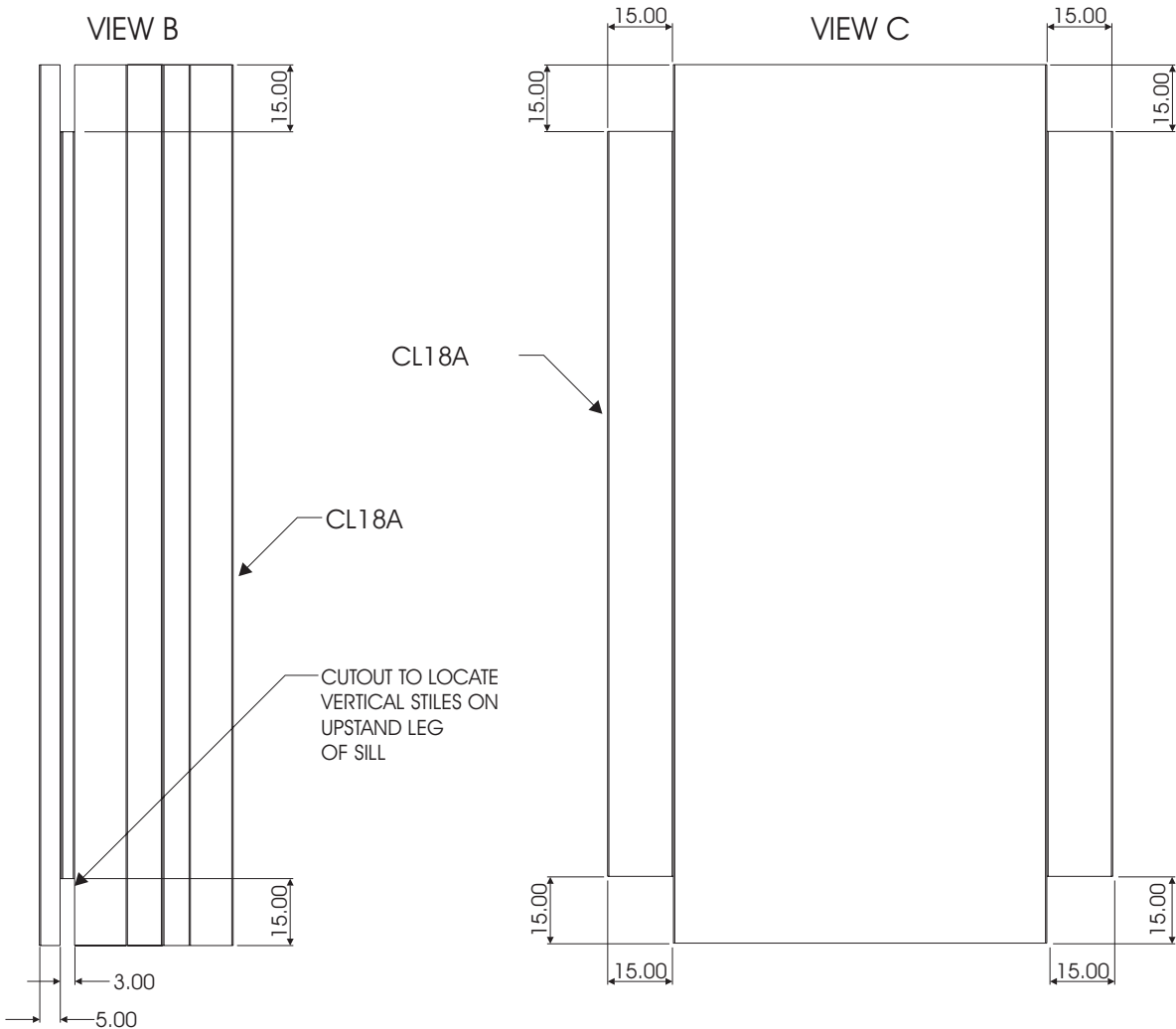
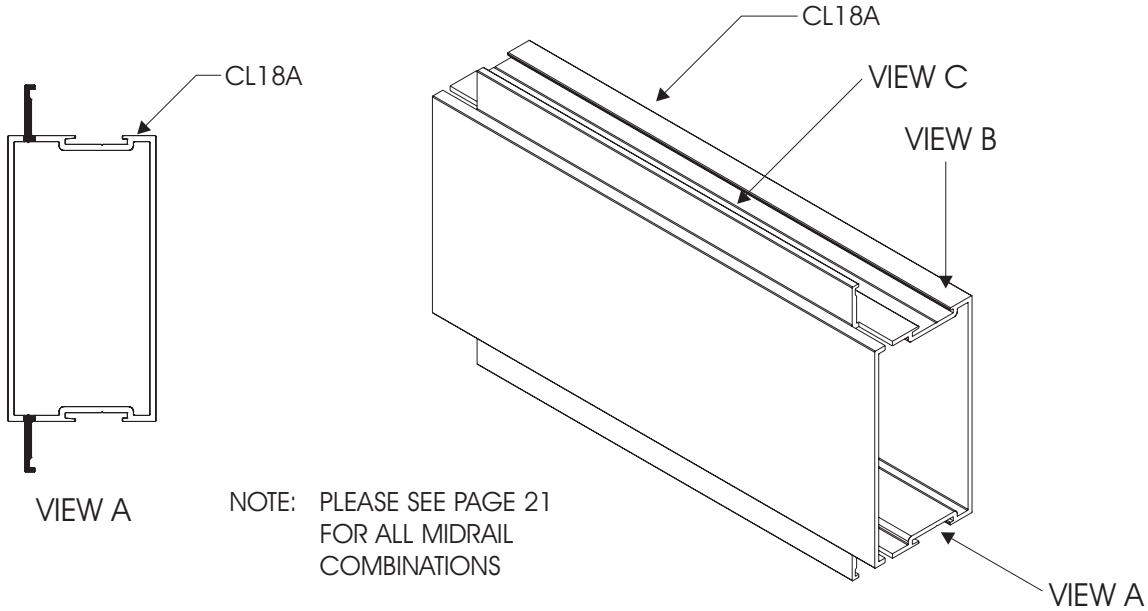

# SHEERFRONT CLIP 15 SYSTEM R4 FILLER ADAPTOR MACHINING DETAIL

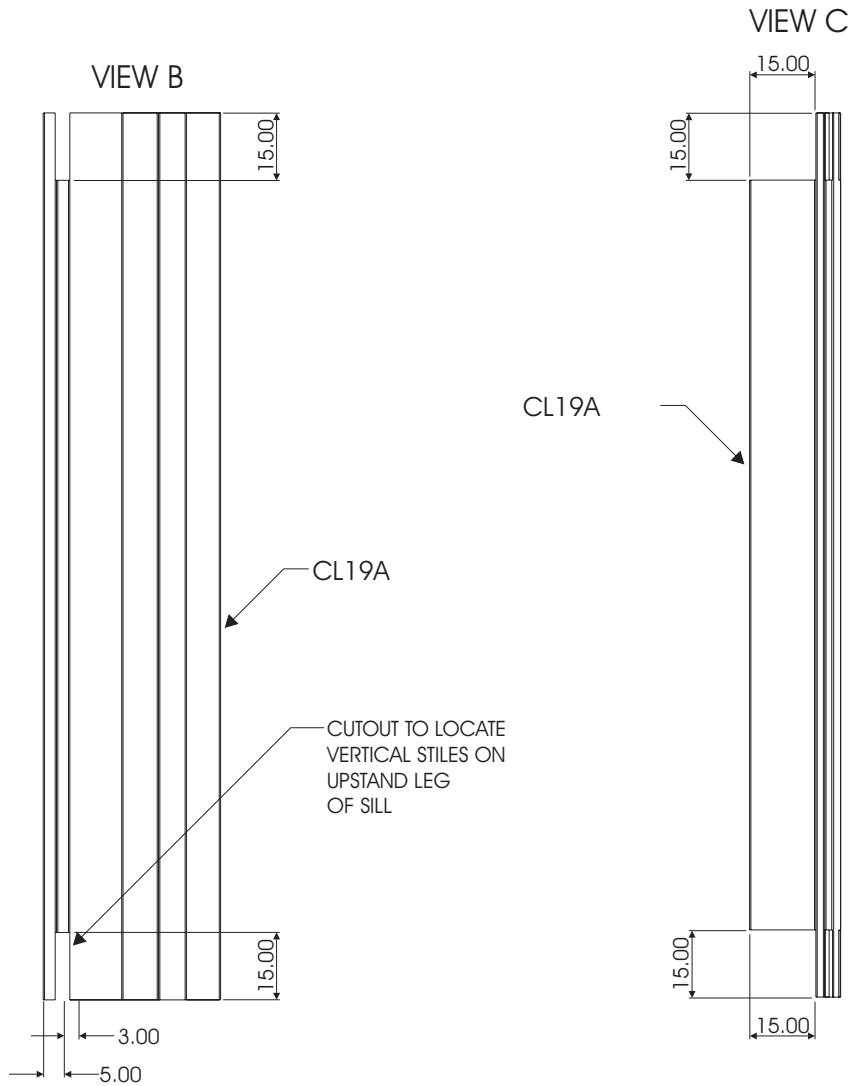
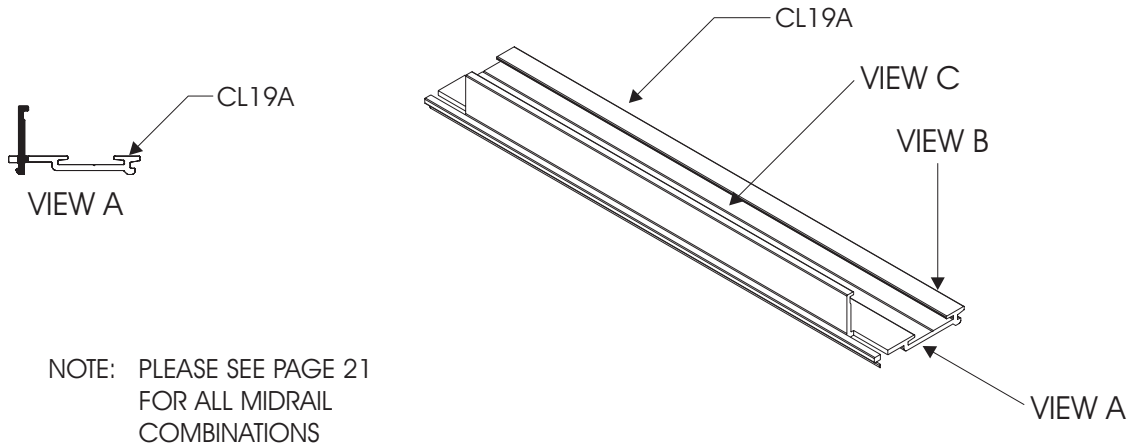

# SHEERFRONT CLIP 15 SYSTEM MIDRAIL COMBINATIONS

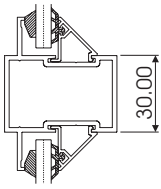

W44  
(CL09A)

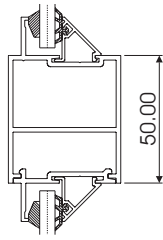

R7 + R4 FILLER  
(CL22A + CL19A)

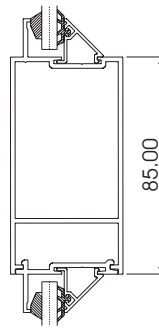

R4 + R4 FILLER  
(CL17A + CL19A)



R4SP  
(CL18A)

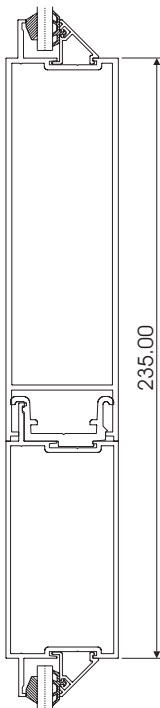

R6 + R4SP  
(CL56A + CL18A)

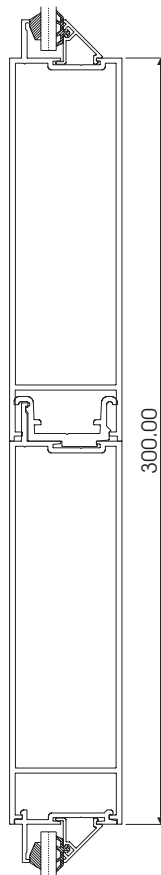

R6 + R6 + R4 FILLER  
(CL56A + CL56A +  
CL19A)

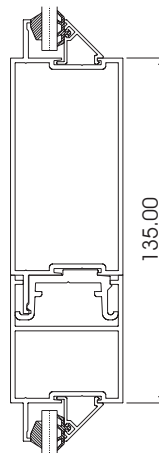

R7 + R4SP  
(CL22A + CL18A)

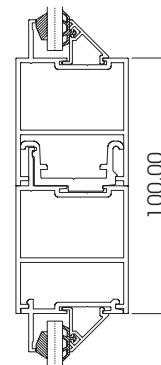

R7 + R7 + R4 FILLER  
(CL22A + CL22A +  
CL19A)



R6 + R4 FILLER  
(CL56A + CL19A)

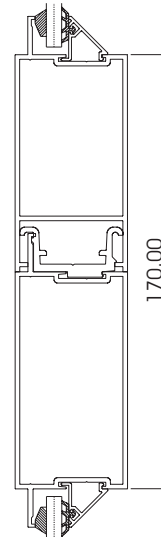

R4 + R4SP  
(CL17A + CL18A)

SHEERFRONT CLIP 15 SYSTEM  
SPIGOT MACHINING DETAIL  
CL25A

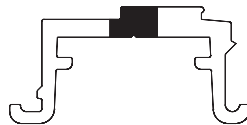
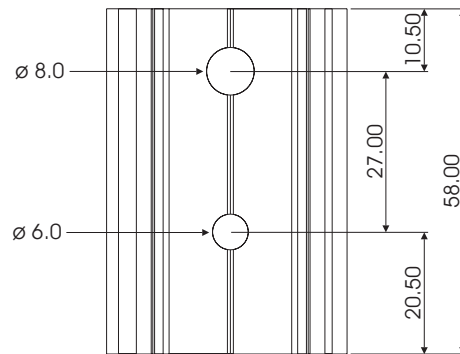
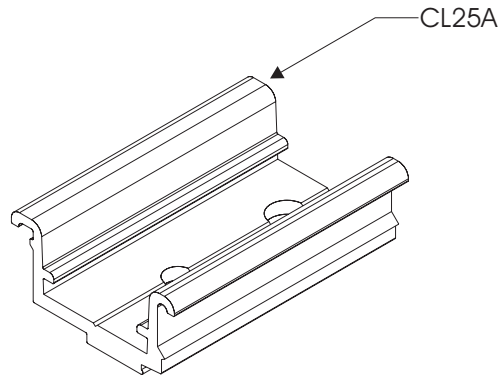

# SHEERFRONT CLIP 15 SYSTEM DOOR STILE MACHINING DETAIL

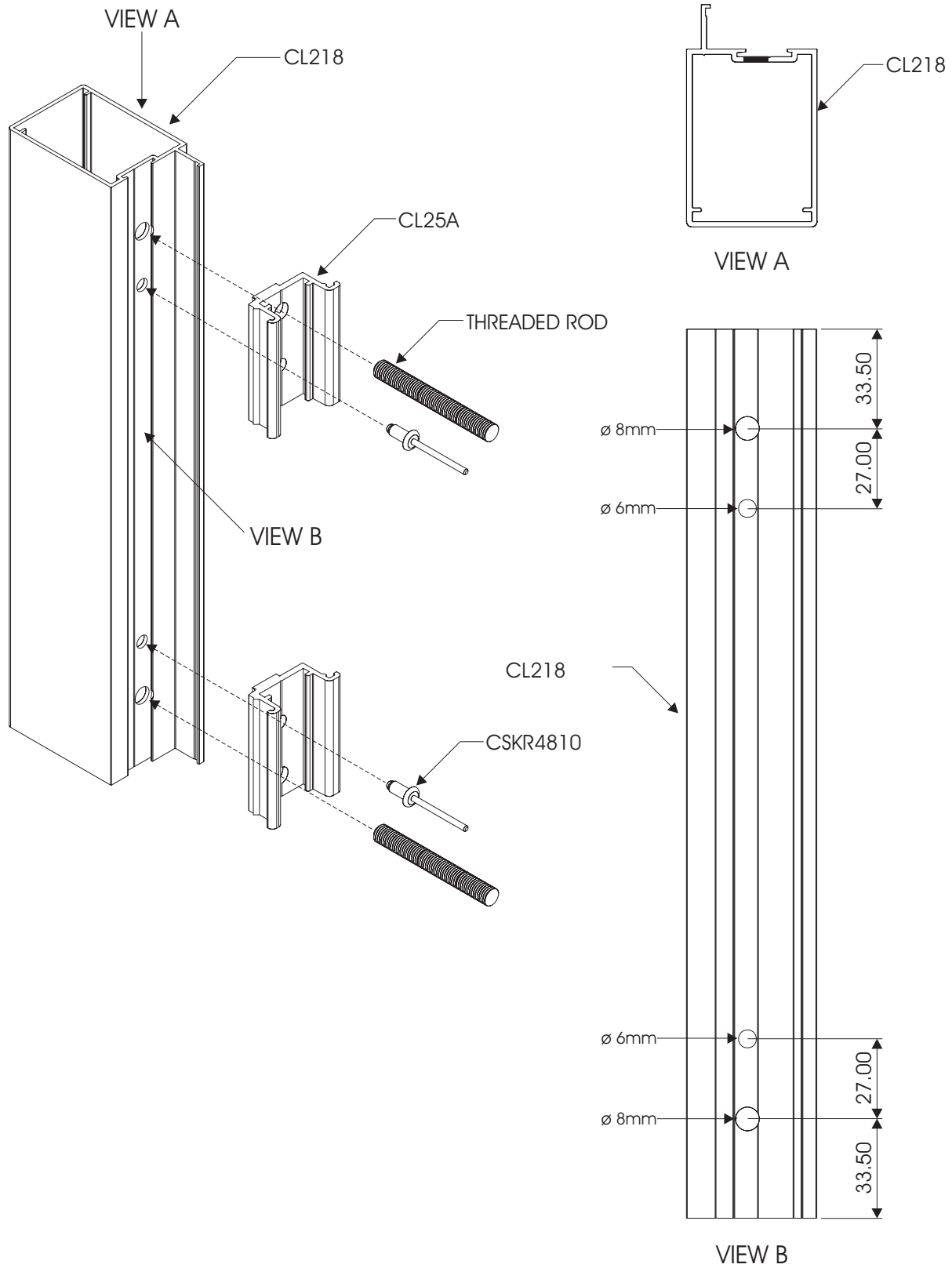

# SHEERFRONT CLIP 15 SYSTEM ROD & SPIGOT ASSEMBLY DETAIL

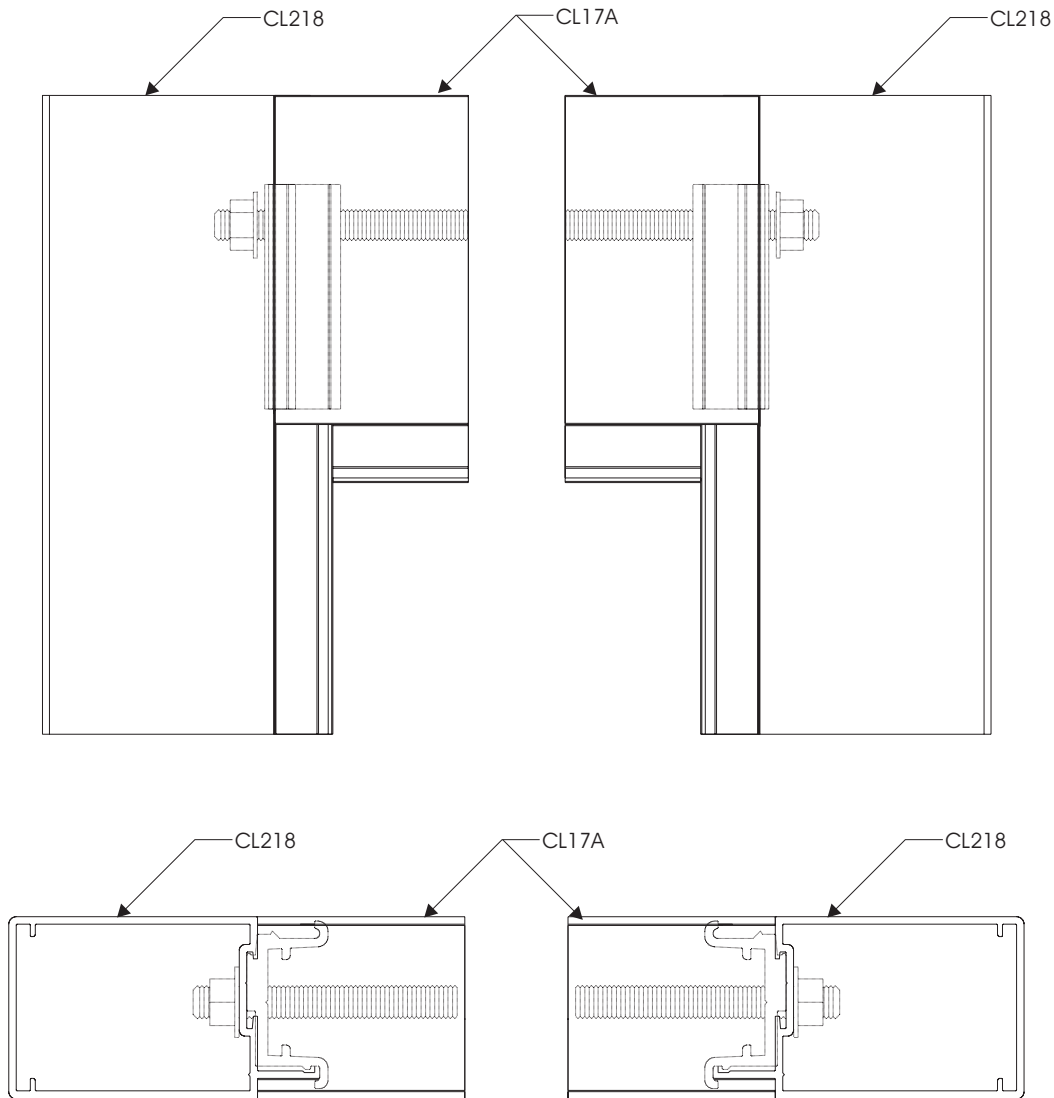

DETAIL TYPICAL TO HEAD AND SILL OF PIVOT DOOR

1. ATTACH SPIGOTS TO STILES WITH NO 8 FIXING SCREWS (SC0840P)
2. FASTEN STILES TO TOP AND BOTTOM RAILS WITH NUTS (SHW07HN) AND THREADED RODS (SHW07). USE WASHERS (SHW07WS).
3. ENSURE ALL MATING JOINTS ARE BEDDED IN SEALANT BEFORE ASSEMBLY.

SHEERFRONT CLIP 15 SYSTEM  
PIVOT DOOR HANDLE  
MACHINING DETAIL  
HNDD25300N

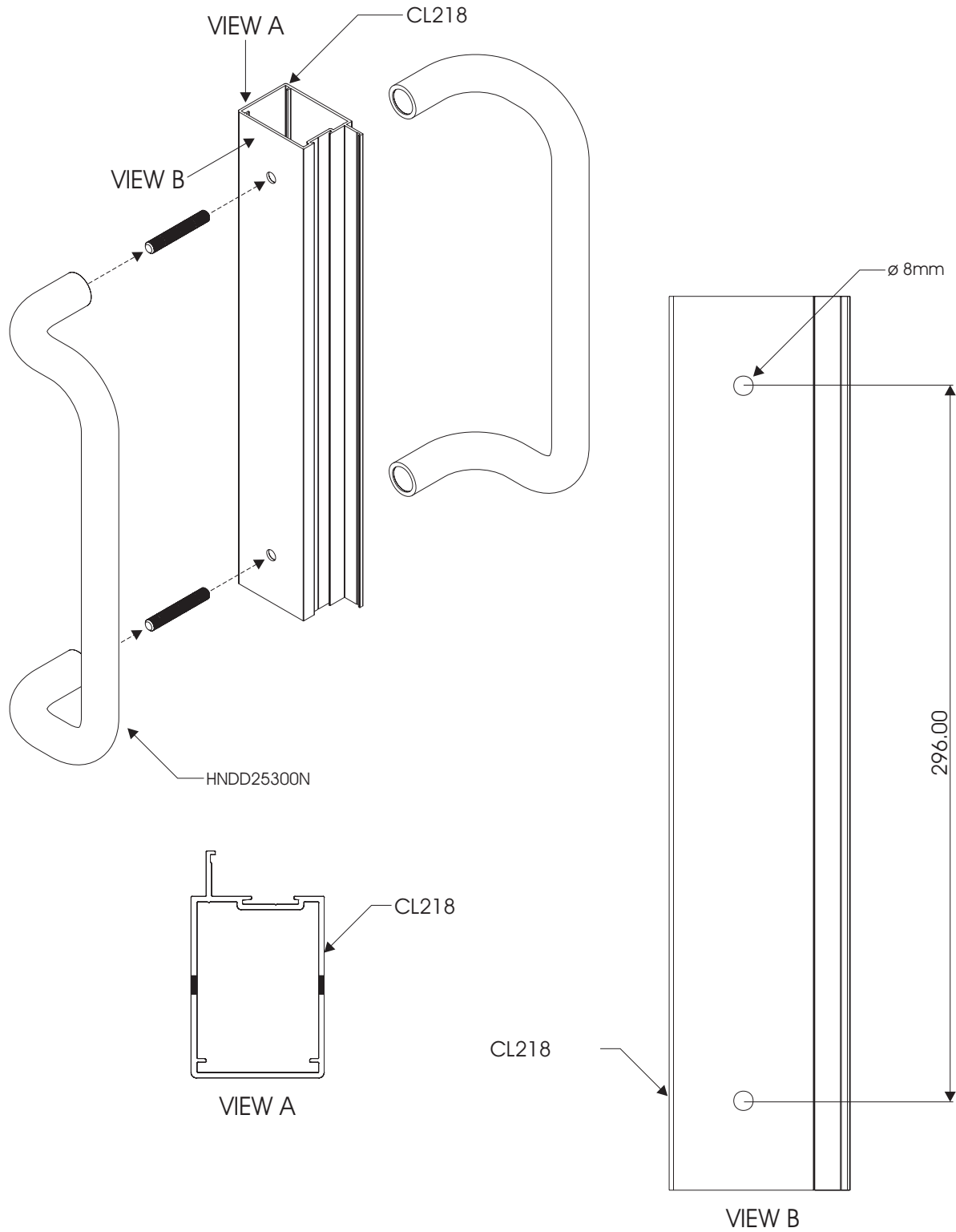

SHEERFRONT CLIP 15 SYSTEM  
 PIVOT DOOR LOCK  
 MACHINING DETAIL  
 CL44640/25

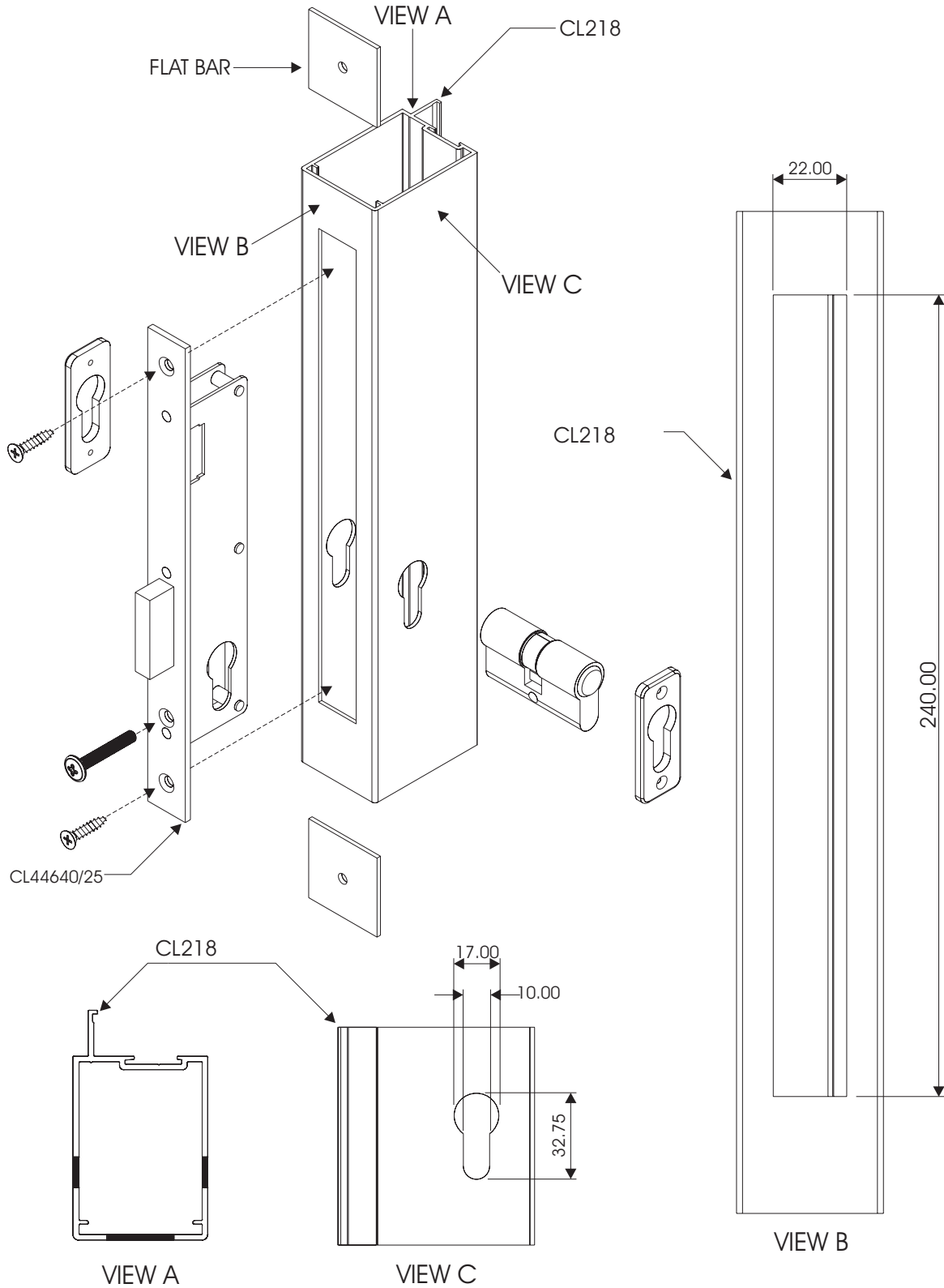

SHEERFRONT CLIP 15 SYSTEM  
 FLUSH BOLT MACHINING DETAIL  
 ON R1 DOOR JAMB USED IN MEETING STILE  
 TO SUIT: R3SP; R9; R9W; R11 & R11W  
 SHW01N

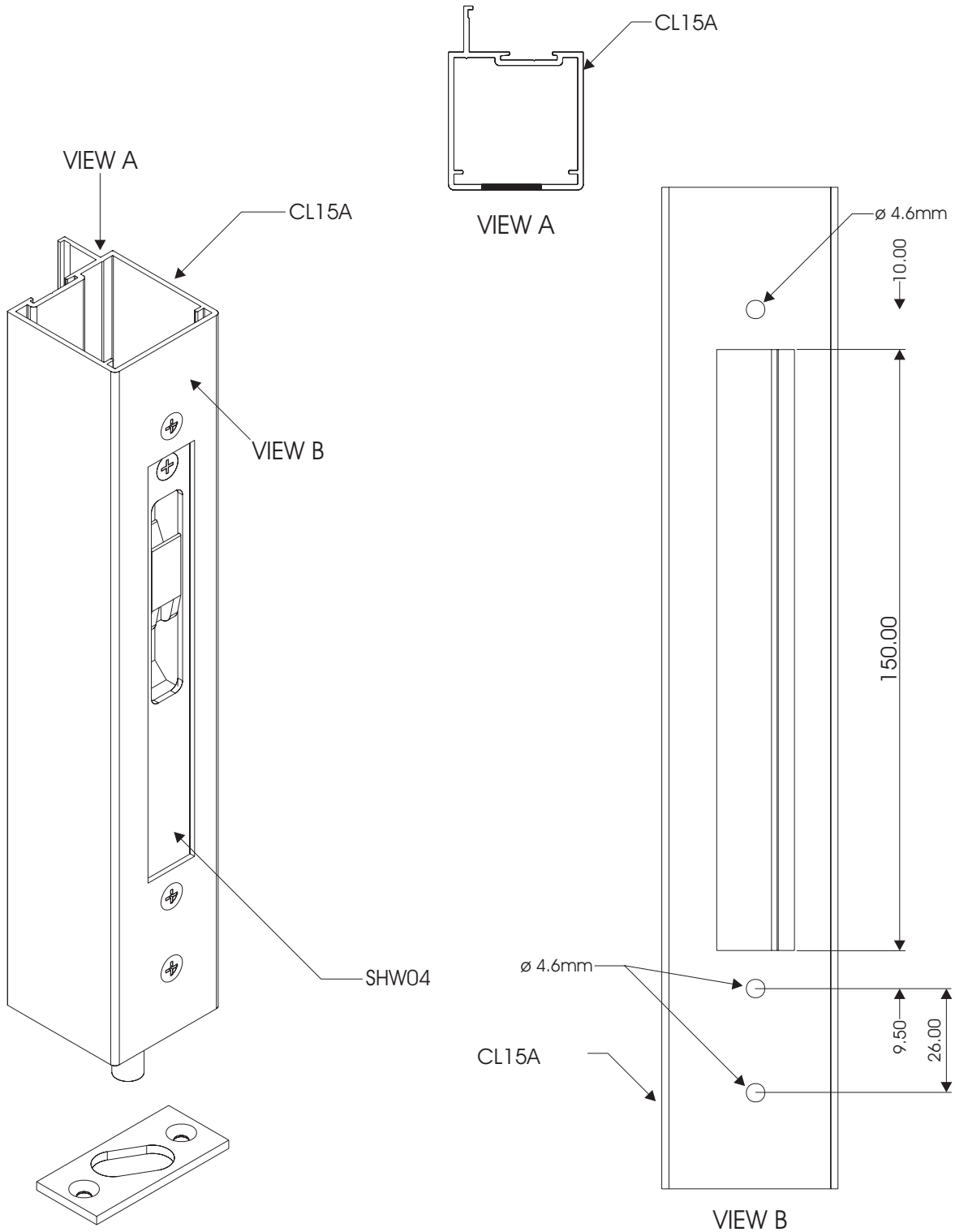

# SHEERFRONT CLIP 15 SYSTEM FLOOR SPRING MACHINING & ASSEMBLY DETAIL ON HEAD SECTION OF PIVOT DOOR

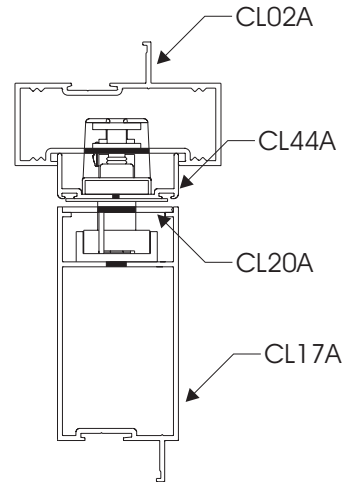
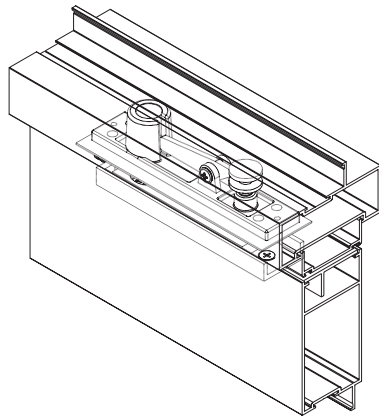

VIEW A

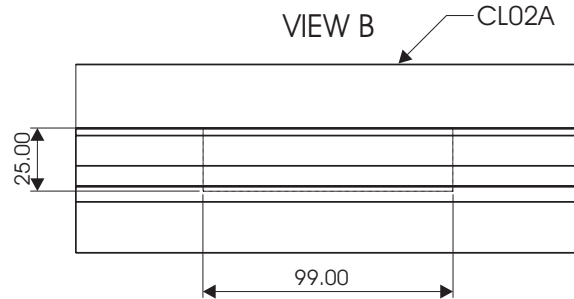
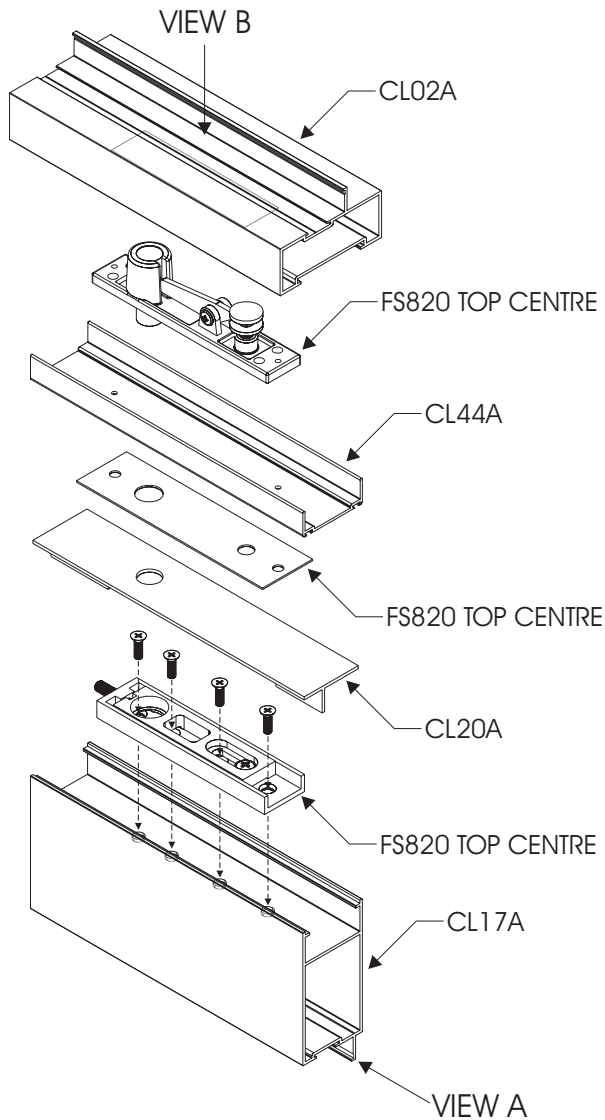

VIEW B CL02A

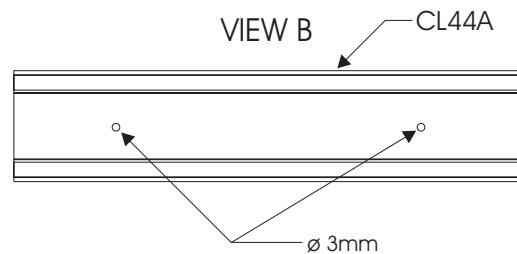

VIEW B CL44A

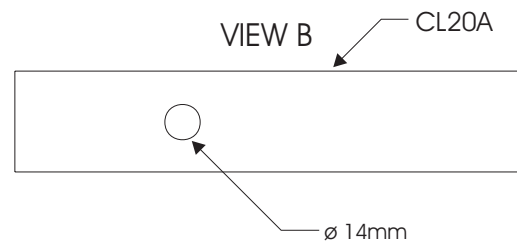

VIEW B CL20A

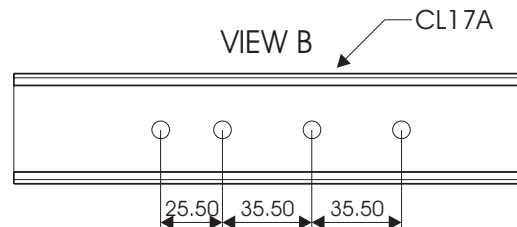

VIEW B CL17A

SHEERFRONT CLIP 15 SYSTEM  
 FLOOR SPRING  
 MACHINING & ASSEMBLY DETAIL  
 ON SILL SECTION OF PIVOT DOOR

