

WISPECO **Aluminium**

SHEERSASH 30.5 WINDOW SYSTEM

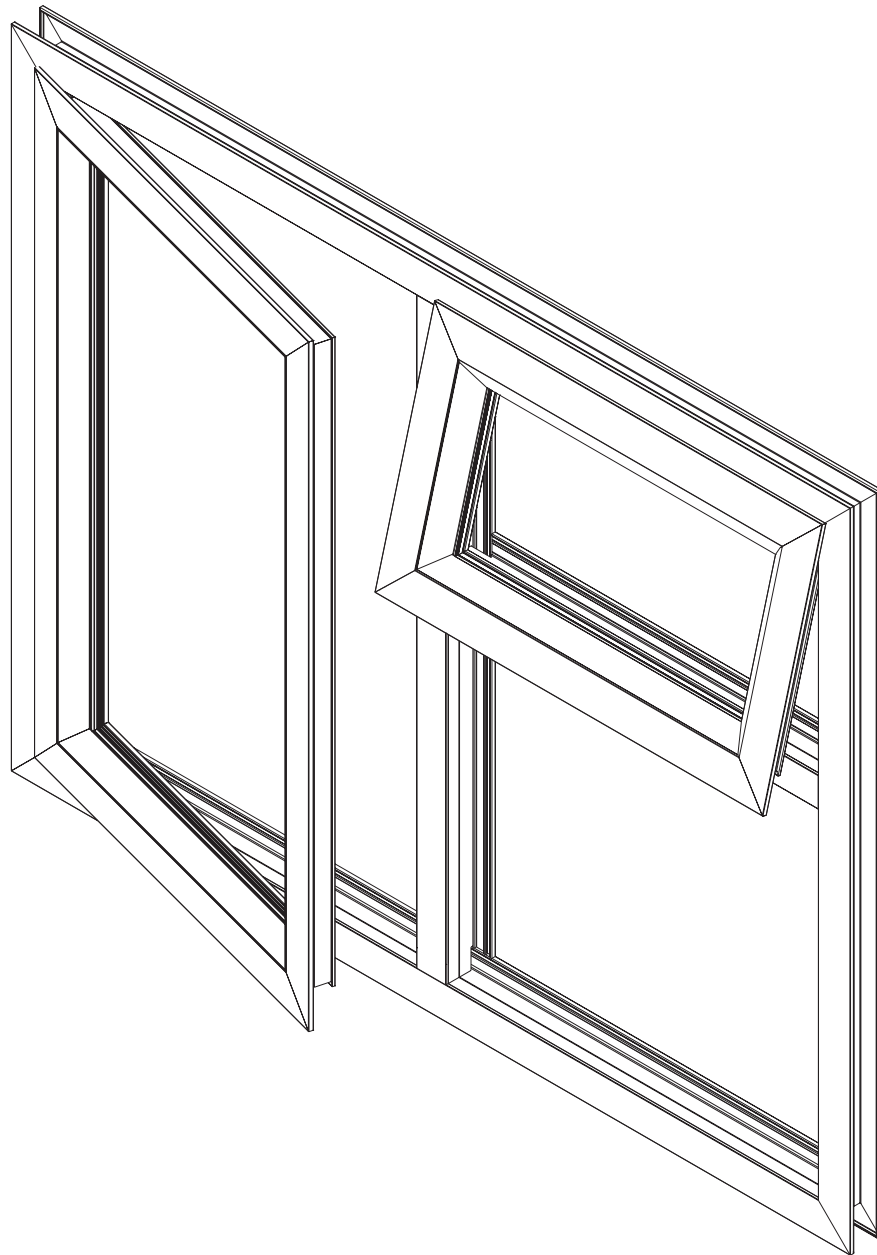

PRODUCT MANUAL

Disclaimer: The right to make alterations is reserved

© 2010 Sheerline, All Rights Reserved

Revision: 01/10/2010



LEGAL DISCLAIMER

All information, recommendations or advice contained in this documentation is given in good faith to the best of Sheerline's knowledge and is based on current procedures in effect.

Since the actual use of this documentation by the user is beyond the control of Sheerline, such use is within the exclusive responsibility of the user. Sheerline cannot be held responsible for any loss incurred through incorrect or faulty use of this documentation.

Great care has been taken to ensure that the information provided is correct. Sheerline will accept no responsibility for any errors and/or omissions, which may have inadvertently occurred.

All mechanical joints must be sealed with a Sheerline approved joint sealer.

Laminated glass must not stand in water.

All drawings in the Sheerline Documentation are shown NOT to scale.

Sheerline cannot accept responsibility for the use of standard products since Sheerline does not know where these products are being installed.

The use of anti-magnetic stainless steel screws and pop rivets is recommended to reduce galvanic corrosion in harsh environments.

The hardware recommended in this documentation is suitable for use in most atmospheric environments. When hardware is used in severe coastal environments the manufacturer of the hardware must be consulted.

Fixing lugs on frames must be positioned as per the user manual and used in accordance to the AAAMSA specifications. When profiles are screwed together the screw centers must also be according to the user manual.

All glass used within Sheerline products must comply with SAGGA regulations.

By continuing to use this documentation you acknowledge that you understand and accept the legal disclaimer.

SHEERSASH 30.5 WINDOW SYSTEM PROFILE IDENTIFICATION

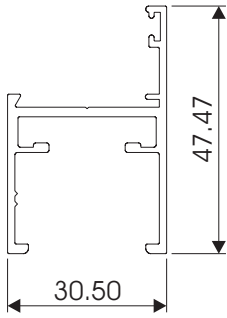

CAS30.5 FRAME 30mm
EQ LEG STD
W27990

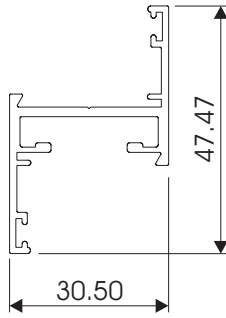

CAS30.5 FRAME 30mm
UNEQ LEG STD
W27992

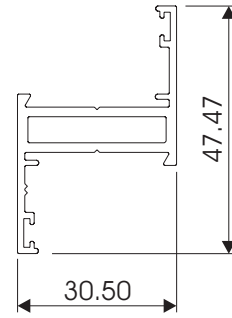

CAS30.5 SASH TUBULAR
STANDARD
W53631

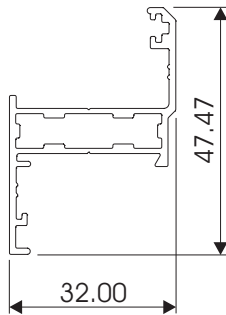

CAS30.5 SASH
PICTURE FRAME
3111A

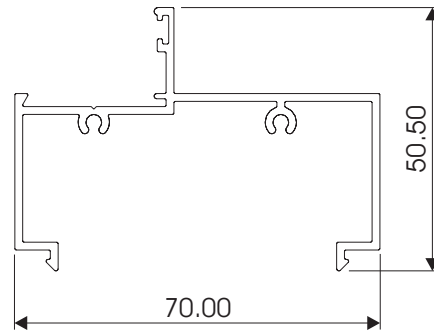

CAS30.5 FRAME 70mm
3120

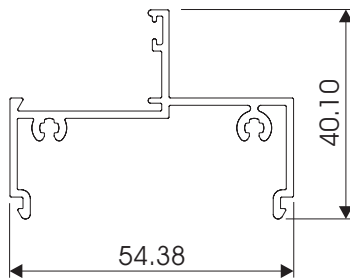

CAS30.5 FRAME 54mm
3119

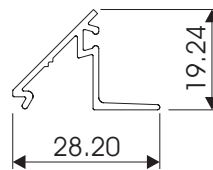

CAS30.5 BEAD
4 & 5mm
3104

SHEERSASH 30.5 WINDOW SYSTEM PROFILE IDENTIFICATION

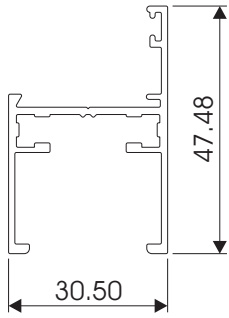

CAS30.5 FRAME 30mm
EQUAL LEG
3101A

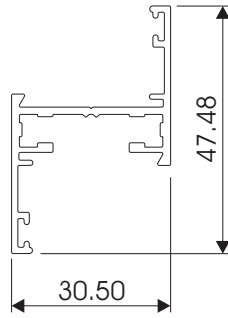

CAS30.5 FRAME 30mm
UNEQUAL LEG
3105A

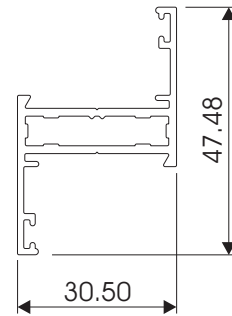

CAS30.5 SASH TUBULAR
3102A

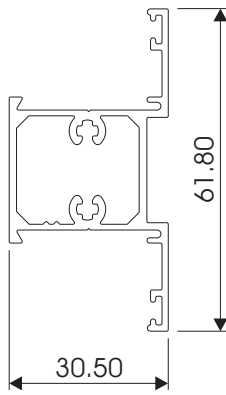

CAS30.5 MULLION 30mm
3103A

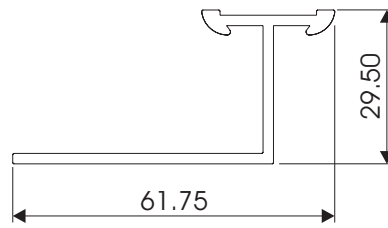

CAS30.5 FIXING LUG
TWIST IN
3109

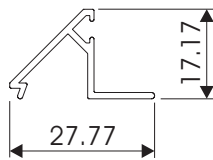

CAS30.5 BEAD 6mm
3108

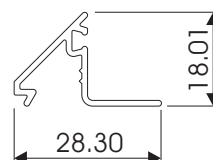

CAS30.5 BEAD MULTI
13mm GAP
3116A

SHEERSASH 30.5 WINDOW SYSTEM PROFILE IDENTIFICATION

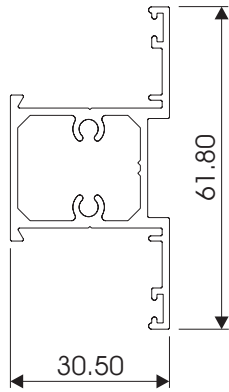

CAS30.5 MULLION 30mm
STANDARD
W53629

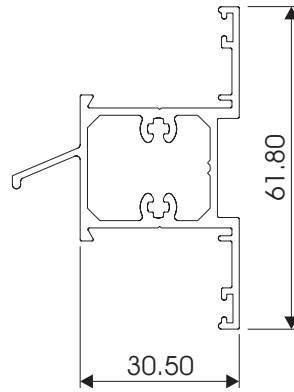

CAS30.5 MULLION 30mm
WEATHER BAR
3106

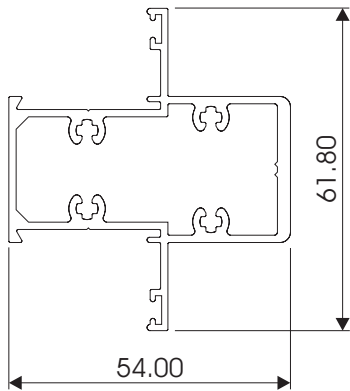

CAS30.5 MULLION 54mm
3113

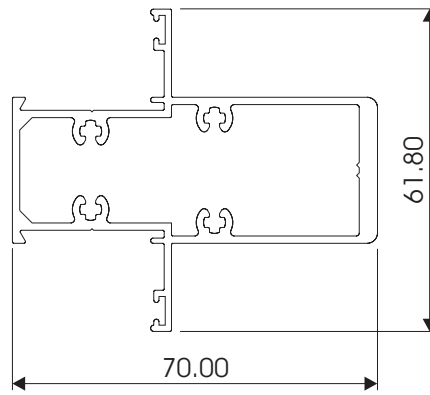

CAS30.5 MULLION 70mm
3117

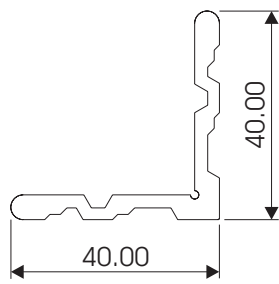

CAS30.5 CORNER CLEAT
40mm
3121

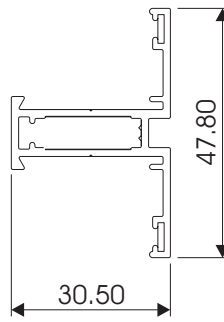

CAS30.5 MULLION 30mm
COTTAGE PANE
3118

SHEERSASH 30.5 WINDOW SYSTEM HARDWARE IDENTIFICATION

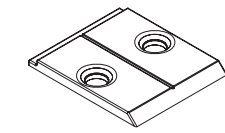

CASEMENT 30.5
GLAZING BAR
PACKER (BLACK)
MP305



8x30 P/HEAD POSI
S/S SCREW
SC0830P



8x9 C/S
HANDLE SCREW
BLUNT POINT
STPPS895

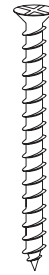

8x40 COUNTERSUNK
POSI S/S SCREWS
SCR0840C

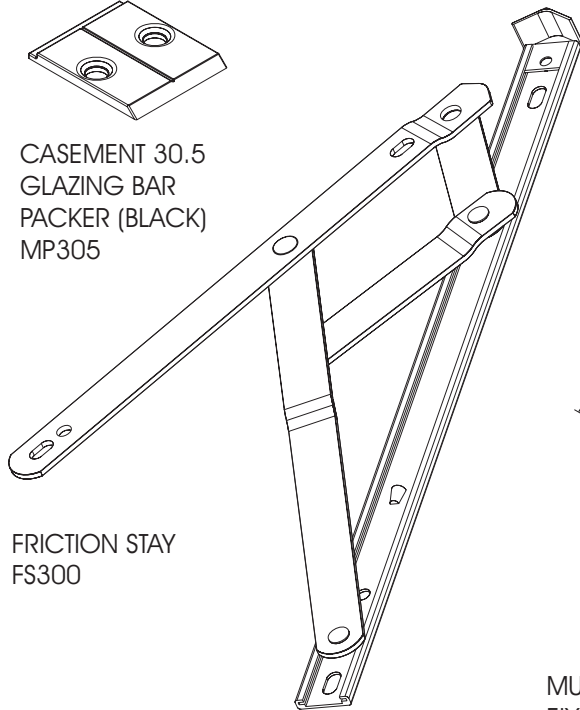

FRICITION STAY
FS300

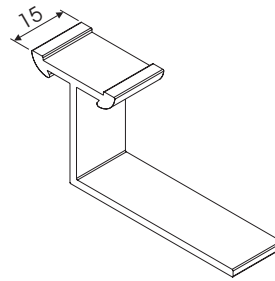

MULTI FIXING LUG ALUM 15mm
FIX29499



4.8 x 10
DOME RIVET
CSKR4810

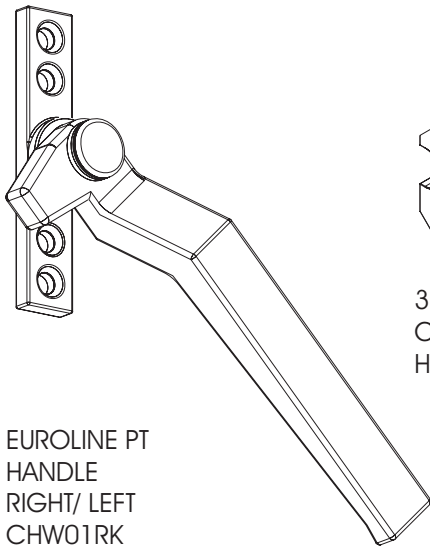

EUROLINE PT
HANDLE
RIGHT/ LEFT
CHW01RK
CHW01LK

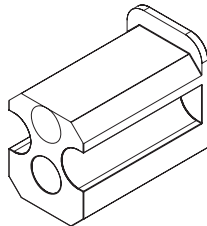

30.5 CROSS
CONNECTOR (BLACK)
HW3103

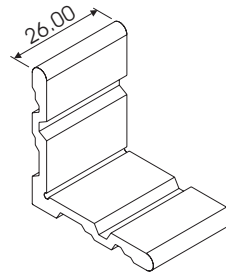

30.5 CASELITE
CORNER CLEAT
HW2803



4 x 10
COUNTERSUNK RIVET
PDHS04

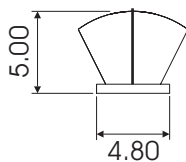

FINPILE
WP4850

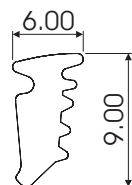

WEDGE H1
VR313FG

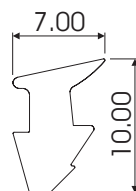

WEDGE H42
VR5123FG

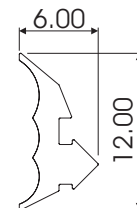

BUTTERFLY H8
VP512FG

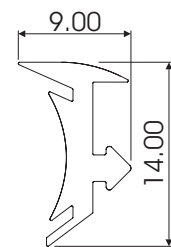

BUTTERFLY H20
VP300FG

Disclaimer: The right to make alterations is reserved
© 2010 Sheerline, All Rights Reserved

SHEERSASH 30.5 WINDOW SYSTEM FRICTION STAY GUIDE



STAINLESS STEEL FRICTION STAYS (HANDED)

1. STANDARD PURPOSE

1.1 TOP HUNG

REF. NO	MAX VENT HEIGHT IN mm	MAX VENT WIDTH IN mm	MAX VENT WEIGHT IN kg	ANGLE OF OPENING degrees
150	300	1200	10	50
200	350	1200	12	50
250	400	1200	16	80
300	550	1200	20	80
400	750	1200	21	80
500	1000	1200	24	50
500	850	1200	24	50
600	1200	1200	35	34.5

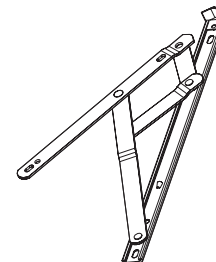

1.2 SIDE HUNG

REF. NO	MAX VENT HEIGHT IN mm	MAX VENT WIDTH IN mm	MAX VENT WEIGHT IN kg	ANGLE OF OPENING degrees
300	1300	600	22	60
300 C	1300	600	22	60
400	1300	700	24	60

2. HEAVY DUTY

2.1 TOP HUNG

REF. NO	MAX VENT HEIGHT IN mm	MAX VENT WIDTH IN mm	MAX VENT WEIGHT IN kg	ANGLE OF OPENING degrees
ST10	635	2000	37	50
ST12	787	2000	45	50
ST16	1090	2000	55	50
ST22	1500	2000	75	45
ST26	2000	2000	100	20
730A	2000	2200	120	10, 13 & 15

2.2 SIDE HUNG

REF. NO	MAX VENT HEIGHT IN mm	MAX VENT WIDTH IN mm	MAX VENT WEIGHT IN kg	ANGLE OF OPENING degrees
STS10	1524	660	38	85
STS16	1625	838	47	90

SHEERSASH 30.5 WINDOW SYSTEM FRICTION STAY GUIDE



STAINLESS STEEL FRICTION STAYS (NON HANDED)

1. TOP HUNG - 4 BAR

REF. NO	MAX VENT HEIGHT IN mm	MAX VENT WIDTH IN mm	MAX VENT WEIGHT IN kg	ANGLE OF OPENING degrees
203	300	1100	7	70
254	375	1100	8	57
300	450	1100	10	90
406	600	1100	13	90
508	750	1100	16	50
610	900	1100	26	60
570 HD	1200	1100	40	90

2. SIDE HUNG - 5 BAR

REF. NO	MAX VENT HEIGHT IN mm	MAX VENT WIDTH IN mm	MAX VENT WEIGHT IN kg	ANGLE OF OPENING degrees
300	1300	600	22	60

FOUR BAR ALUMINIUM FRICTION HINGE HEAVY DUTY

1. TOP HUNG

REF. NO	MAX VENT HEIGHT IN mm	MAX VENT WEIGHT IN kg	ANGLE OF OPENING degrees
200 N4B	600	6	49
200 N4B V	400	6	30
250 N4B	750	6	49
300 N4B	1000	7	38
500 N4B	1300	12	29
750 N4B	1800	13	27

2. SIDE HUNG

REF. NO	MAX VENT HEIGHT IN mm	MAX VENT WEIGHT IN kg	ANGLE OF OPENING degrees
300 N4B C	600	20	54
300 N4B C	750	16	54

SHEERSASH 30.5 WINDOW SYSTEM SASH LIMITATION CHARTS



		Maximum Vent Width in mm	Maximum Vent Height in mm
Top Hung	W53631	1000	750

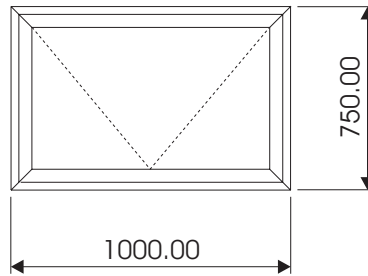

		Maximum Vent Width in mm	Maximum Vent Height in mm
Side Hung	W53631	600	1200

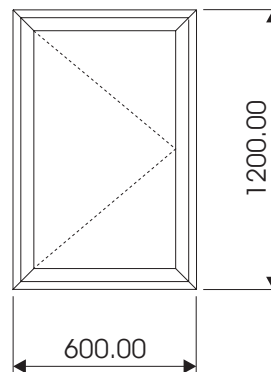

STANDARD TOP HUNG SHEERSASH 30.5 WINDOWS 600Pa WINDLOAD



NOTE:

1. SEE THE MULLION LIMITATION CHART
2. OPENING SIZES SHOWN IN RED
3. ACTUAL WINDOW SIZES SHOWN IN BLACK AND BRACKETS.

	600 (590)	900 (890)	1 200 (1190)	1 500 (1490)	1 800 (1790)	2 400 (2390)
600 (590)	 30.5-0606T	 30.5-0906T	 30.5-1206T	 30.5-1506T	 30.5-1806TT	 30.5-2406TT
900 (890)	 30.5-0609T	 30.5-0909T	 30.5-1209T	 30.5-1509T	 30.5-1809TT	 30.5-2409TT
1200 (1190)	 30.5-0612T	 30.5-0912T	 30.5-1212DT	 30.5-1512DT	 30.5-1812DT	 30.5-2412DT
1500 (1490)	 30.5-0615DT	 30.5-0915DT	 30.5-1215DT 54mm Mull3113	 30.5-1515DT 54mm Mull3113	 30.5-1815DT 54mm Mull3113	 30.5-2415DT 54mm Mull3113
1800 (1790)	 30.5-0618DT	 30.5-0918DT	 30.5-1218DT 54mm Mull3113	 30.5-1518DT 54mm Mull3113	 30.5-1818DT 54mm Mull3113	 30.5-2418DT 54mm Mull3113

STANDARD TOP HUNG SHEERSASH 30.5 WINDOWS 1000Pa WINDLOAD



NOTE:

1. SEE THE MULLION LIMITATION CHART
2. OPENING SIZES SHOWN IN RED
3. ACTUAL WINDOW SIZES SHOWN IN BLACK AND BRACKETS.

	600 (590)	900 (890)	1 200 (1190)	1 500 (1490)	1 800 (1790)	2 400 (2390)
600 (590)	 30.5 -0606T	 30.5 -0906T	 30.5 -1206T	 30.5 -1506T	 30.5 -1806T	 30.5 -2406T
900 (890)	 30.5 -0609T	 30.5 -0909T	 30.5 -1209T	 30.5 -1509T	 30.5 -1809T	 30.5 -2409T
1200 (1190)	 30.5 -0612T	 30.5 -0912T	 30.5 -1212DT	 30.5 -1512DT 54mm Mull 3113	 30.5 -1812DT 54mm Mull 3113	 30.5 -2412DT 54mm Mull 3113
1500 (1490)	 30.5 -0615DT	 30.5 -0915DT	 30.5 -1215DT 54mm Mull3113	 30.5 -1515DT 54mm Mull3113	 30.5 -1815DT 54mm Mull3113	 30.5 -2415DT 54mm Mull3113
1800 (1790)	 30.5 -0618DT	 30.5 -0918DT	 30.5 -1218DT 54mm Mull3113	 30.5 -1518DT 54mm Mull3117	 30.5 -1818DT 54mm Mull3117	 30.5 -2418DT 54mm Mull3117

STANDARD TOP HUNG SHEERSASH 30.5 WINDOWS 1500Pa WINDLOAD



NOTE:

1. SEE THE MULLION LIMITATION CHART
2. OPENING SIZES SHOWN IN RED
3. ACTUAL WINDOW SIZES SHOWN IN BLACK AND BRACKETS.

	600 (590)	900 (890)	1 200 (1190)	1 500 (1490)	1 800 (1790)	2 400 (2390)
600 (590)	 30.5-0606T	 30.5-0906T	 30.5-1206T	 30.5-1506T	 30.5-1806TT	 30.5-2406TT
900 (890)	 30.5-0609T	 30.5-0909T	 30.5-1209T	 30.5-1509T	 30.5-1809TT	 30.5-2409TT
1200 (1190)	 30.5-0612T	 30.5-0912T	 30.5-1212DT 54mm Mull 3113	 30.5-1512DT 54mm Mull 3113	 30.5-1812DT 54mm Mull 3113	 30.5-2412DT 54mm Mull 3113
1500 (1490)	 30.5-0615DT	 30.5-0915DT	 30.5-1215DT 54mm Mull 3113	 30.5-1515DT 54mm Mull 3113	 30.5-1815DT 70mm Mull 3117	 30.5-2415DT 70mm Mull 3117
1800 (1790)	 30.5-0618DT	 30.5-0918DT	 30.5-1218DT 70mm Mull 3117	 30.5-1518DT 70mm Mull 3117	 30.5-1818DT 70mm Mull 3117	 30.5-2418DT 70mm Mull 3117

STANDARD SIDE HUNG SHEERSASH 30.5 WINDOWS 600Pa WINDLOAD



NOTE:

1. SEE THE MULLION LIMITATION CHART
2. OPENING SIZES SHOWN IN RED
3. ACTUAL WINDOW SIZES SHOWN IN BLACK AND BRACKETS.

	600 (590)	900 (890)	1 200 (1190)	1 500 (1490)	1 800 (1790)	2 400 (2390)
600 (590)						
900 (890)	 305 -0609S	 305 -0909S	 305 -1209S	 305 -1509S	 305 -1809SS	 305 -2409SS
1200 (1190)	 305 -0612S	 305 -0912S	 305 -1212S	 305 -1512S	 305 -1812SS	 305 -2412SS
1500 (1490)	 305 -0615S	 305 -0915S	 305 -1215S 54mm Mull3113	 305 -1515S 54mm Mull3113	 305 -1815SS 54mm Mull3113	 305 -2415SS 54mm Mull3113
1800 (1790)	 305 -0618S	 305 -0918S 54mm Mull3113	 305 -1218S 54mm Mull3113	 305 -1518S 54mm Mull3113	 305 -1818SS 54mm Mull3113	 305 -2418SS 54mm Mull3113

STANDARD SIDE HUNG SHEERSASH 30.5 WINDOWS 1000Pa WINDLOAD



NOTE:

1. SEE THE MULLION LIMITATION CHART
2. OPENING SIZES SHOWN IN RED
3. ACTUAL WINDOW SIZES SHOWN IN BLACK AND BRACKETS.



	600 (590)	900 (890)	1 200 (1190)	1 500 (1490)	1 800 (1790)	2 400 (2390)
600 (590)						
900 (890)	 305 -0609S	 305 -0909S	 305 -1209S	 305 -1509S 54mm Mull 3113	 305 -1809SS	 305 -2409SS 54mm Mull 3113
1200 (1190)	 305 -0612S	 305 -0912S	 305 -1212S 54mm Mull 3113	 305 -1512S 54mm Mull 3113	 305 -1812SS	 305 -2412SS 54mm Mull 3113
1500 (1490)	 305 -0615S	 305 -0915S 54mm Mull 3113	 305 -1215S 54mm Mull 3113	 305 -1515S 54mm Mull 3113	 305 -1815SS 54mm Mull 3113	 305 -2415SS 54mm Mull 3113
1800 (1790)	 305 -0618S	 305 -0918S 54mm Mull 3113	 305 -1218S 54mm Mull 3113	 305 -1518S 70mm Mull 3117	 305 -1818SS 54mm Mull 3113	 305 -2418SS 70mm Mull 3117

STANDARD SIDE HUNG SHEERSASH 30.5 WINDOWS 1500Pa WINDLOAD



NOTE:

1. SEE THE MULLION LIMITATION CHART
2. OPENING SIZES SHOWN IN RED
3. ACTUAL WINDOW SIZES SHOWN IN BLACK AND BRACKETS.

	600 (590)	900 (890)	1 200 (1190)	1 500 (1490)	1 800 (1790)	2 400 (2390)
600 (590)						
900 (890)	 305 -0609S	 305 -0909S	 305 -1209S	 305 -1509S 54mm Mull 3113	 305 -1809SS	 305 -2409SS 54mm Mull 3113
1200 (1190)	 305 -0612S	 305 -0912S 54mm Mull 3113	 305 -1212S 54mm Mull 3113	 305 -1512S 54mm Mull 3113	 305 -1812SS 54mm Mull 3113	 305 -2412SS 54mm Mull 3113
1500 (1490)	 305 -0615S	 305 -0915S 54mm Mull 3113	 305 -1215S 54mm Mull 3113	 305 -1515S 54mm Mull 3113	 305 -1815SS 54mm Mull 3113	 305 -2415SS 70mm Mull 3117
1800 (1790)	 305 -0618S	 305 -0918S 70mm Mull 3117	 305 -1218S 70mm Mull 3117	 305 -1518S 70mm Mull 3117	 305 -1818SS 70mm Mull 3117	 305 -2418SS 70mm Mull 3117

SHEERSASH 30.5 SYSTEM
STANDARD TOP HUNG WINDOW
TYPICAL CONFIGURATIONS

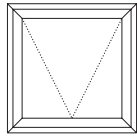

A
SINGLE TOP HUNG

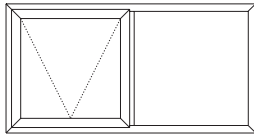

BB
TOP HUNG
NEXT TO FIXED

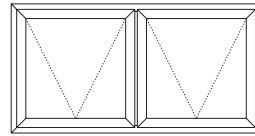

CC
TOP HUNG NEXT
TO TOP HUNG

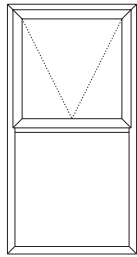

B
TOP HUNG
OVER FIXED

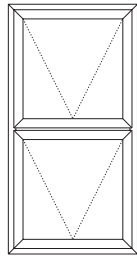

C
TOP HUNG
OVER TOP HUNG

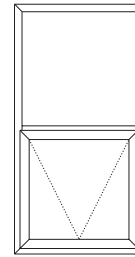

E
FIXED OVER
TOP HUNG

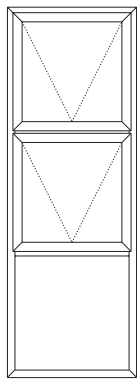

D
DOUBLE TOP HUNG
OVER FIXED

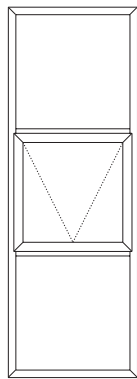

DD
FIXED OVER
TOP HUNG
OVER FIXED

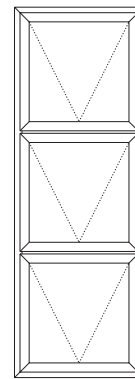

EE
TRIPLE TOP HUNG

SHEERSASH 30.5 SYSTEM
STANDARD SIDE HUNG WINDOW
TYPICAL CONFIGURATIONS

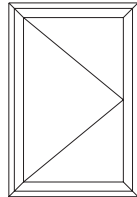

A
SINGLE SIDE HUNG

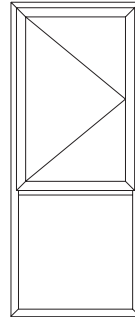

B
SIDE HUNG
OVER FIXED

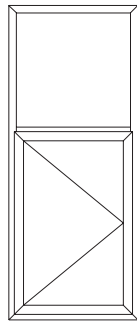

C
FIXED OVER
SIDE HUNG

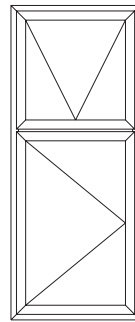

D
TOP HUNG
OVER SIDE HUNG

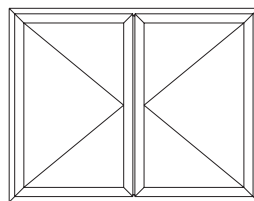

CC
SIDE HUNG NEXT
TO SIDE HUNG

SHEERSASH 30.5 SYSTEM
COTTAGE PANE WINDOW
FIXED PANEL TYPICAL CONFIGURATIONS

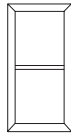

A

1 x 2 FIXED PANEL

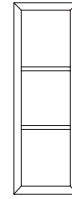

B

1 x 3 FIXED PANEL



C

2 x 1 FIXED PANEL

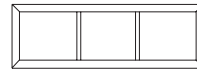

D

3 x 1 FIXED PANEL

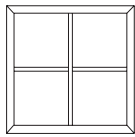

E

2 x 2 FIXED PANEL

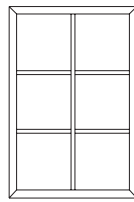

F

2 x 3 FIXED PANEL

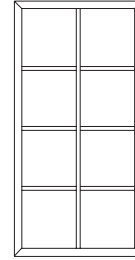

G

2 x 4 FIXED PANEL

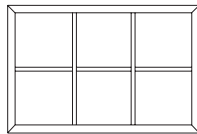

H

3 x 2 FIXED PANEL

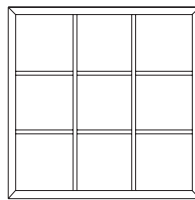

I

3 x 3 FIXED PANEL

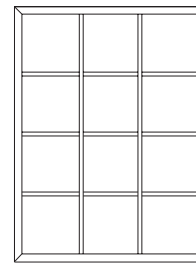

J

3 x 4 FIXED PANEL

SHEERSASH 30.5 SYSTEM
COTTAGE PANE WINDOW
TOP HUNG & SIDE HUNG
TYPICAL CONFIGURATIONS



TOP HUNG

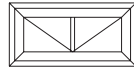

P

2 x 1 PANE
SINGLE TOP HUNG

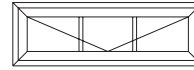

R

3 x 1 PANE
SINGLE TOP HUNG

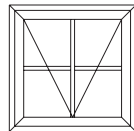

Q

2 x 2 PANE
SINGLE TOP HUNG

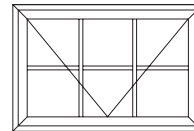

S

3 x 2 PANE
SINGLE TOP HUNG

SIDE HUNG

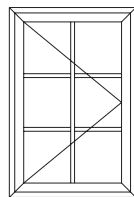

P

2 x 3 PANE
SINGLE SIDE HUNG

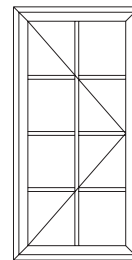

Q

2 x 4 PANE
SINGLE SIDE HUNG

SHEERSASH 30.5 FIXING DETAILS

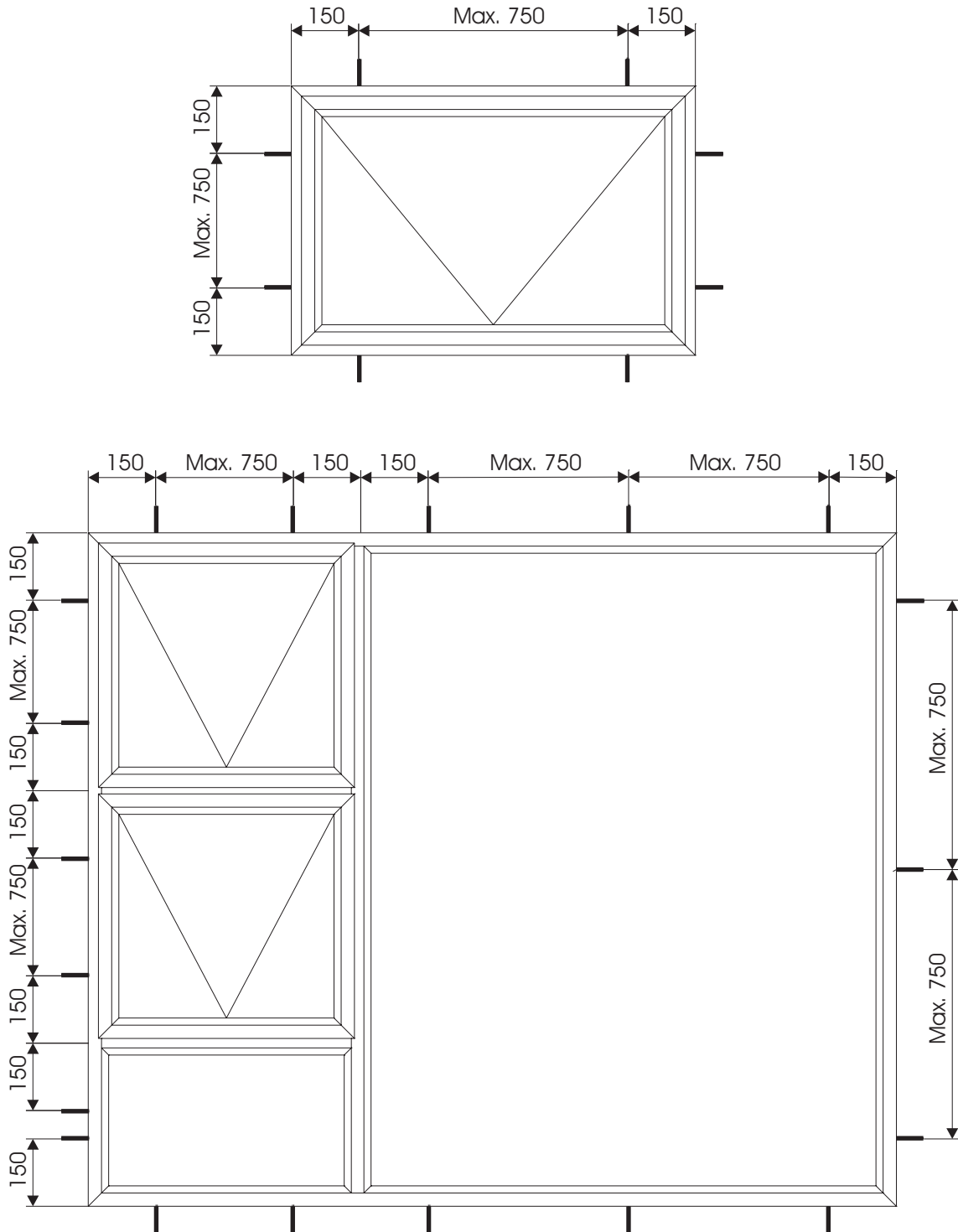

General:

The window is fixed into position - the sill is then built at a later stage - the bottom lugs can be left in place but it is often found that most times the mason either bends them out of his way or breaks them off. This practically means that most windows are only secured on 3 sides.

Disclaimer: The right to make alterations is reserved

© 2010 Sheerline, All Rights Reserved

SHEERSASH 30.5 WINDOW SYSTEM TYPICAL CROSS SECTIONAL DETAIL DOUBLE TOP HUNG OVER FIXED

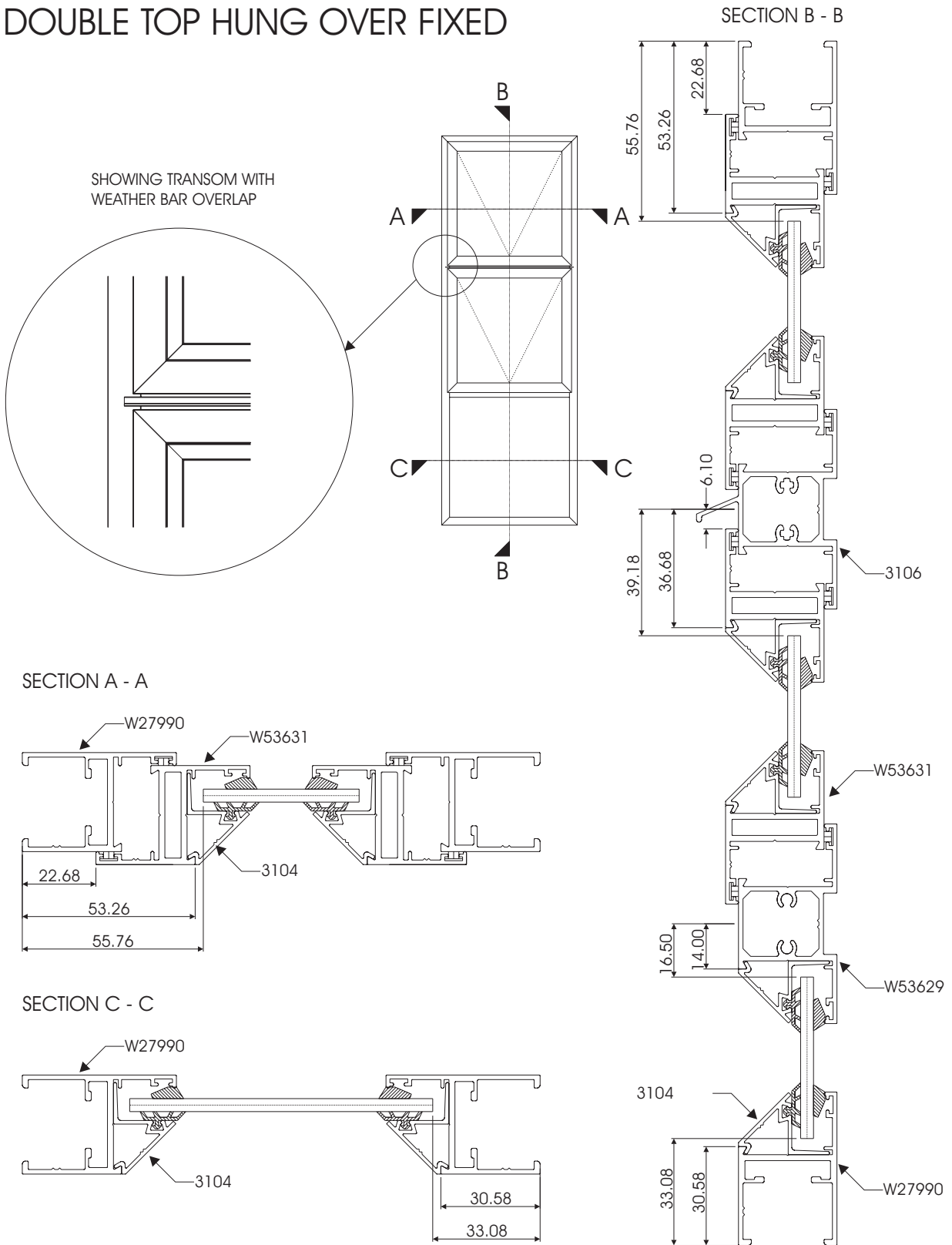

Disclaimer: The right to make alterations is reserved
© 2010 Sheerline, All Rights Reserved

SHEERSASH 30.5 WINDOW SYSTEM TYPICAL CROSS SECTIONAL DETAIL SIDE HUNG OVER FIXED

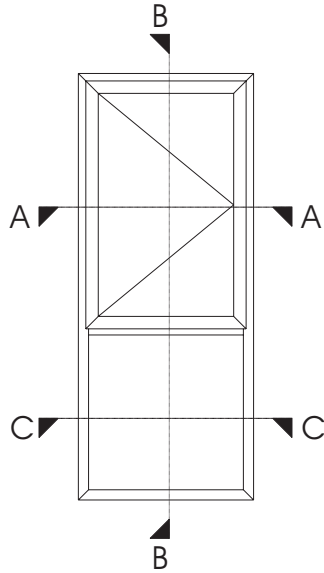

SECTION B - B

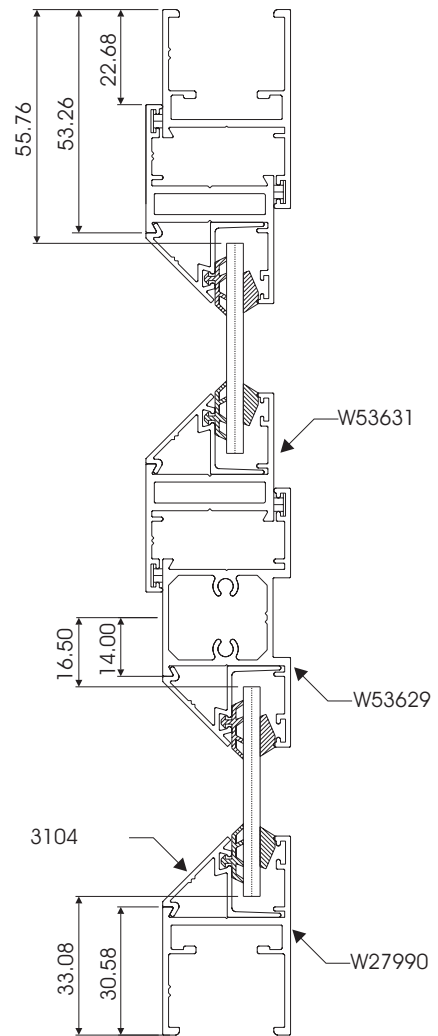

SECTION A - A

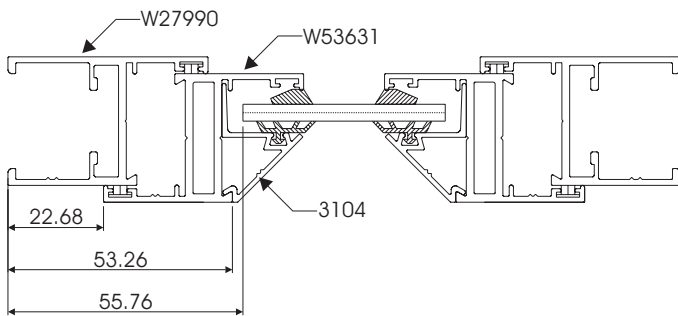

SECTION C - C

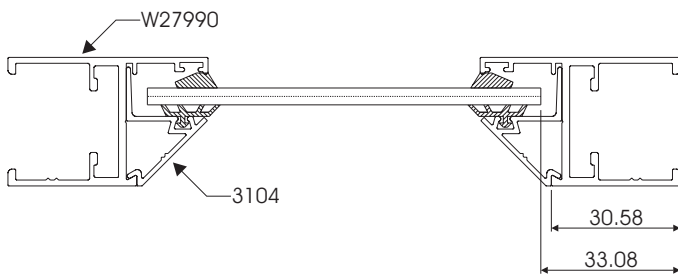

SHEERSASH 30.5 WINDOW SYSTEM
 COTTAGE PANE TYPICAL
 CROSS SECTIONAL DETAIL
 2 x 2 TOP HUNG OVER
 2 x 1 FIXED PANEL

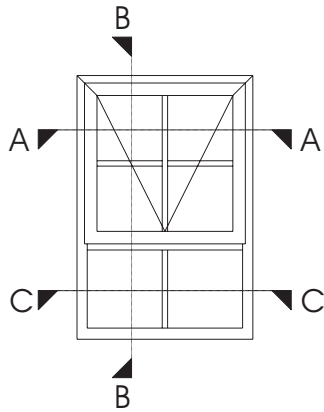

SECTION B - B

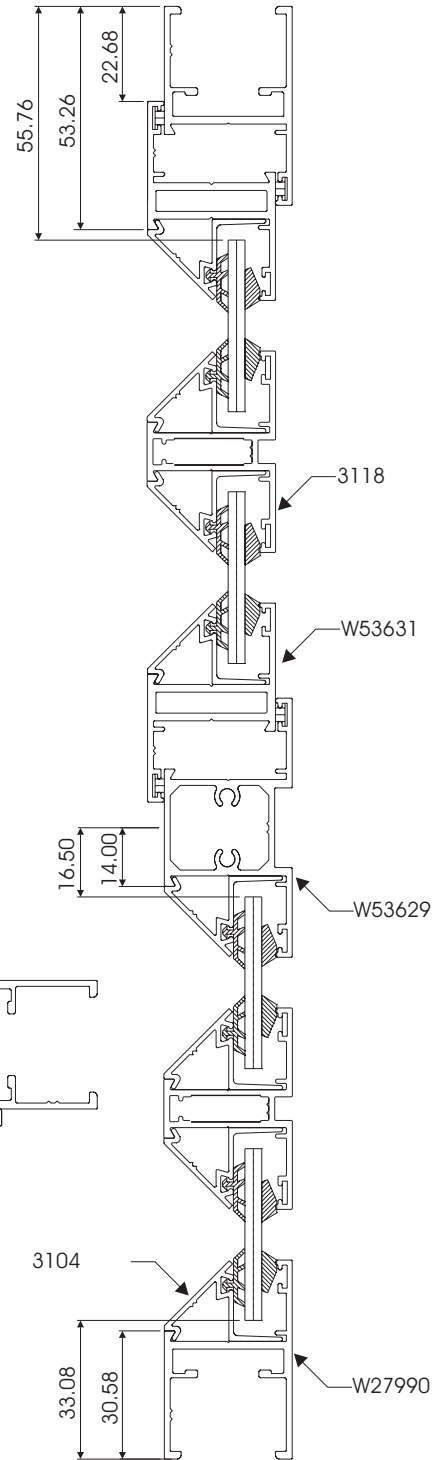

SECTION A - A

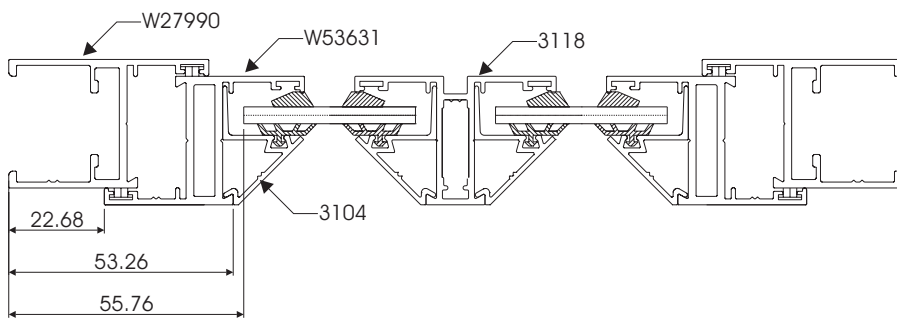

SECTION C - C

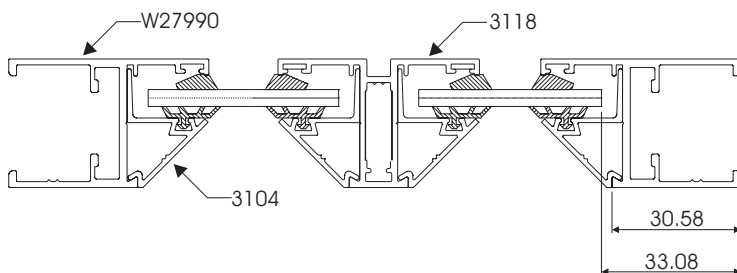

Disclaimer: The right to make alterations is reserved
 © 2010 Sheerline, All Rights Reserved

SHEERSASH 30.5 WINDOW SYSTEM
OUTER FRAME COMPONENT
ASSEMBLY DETAIL

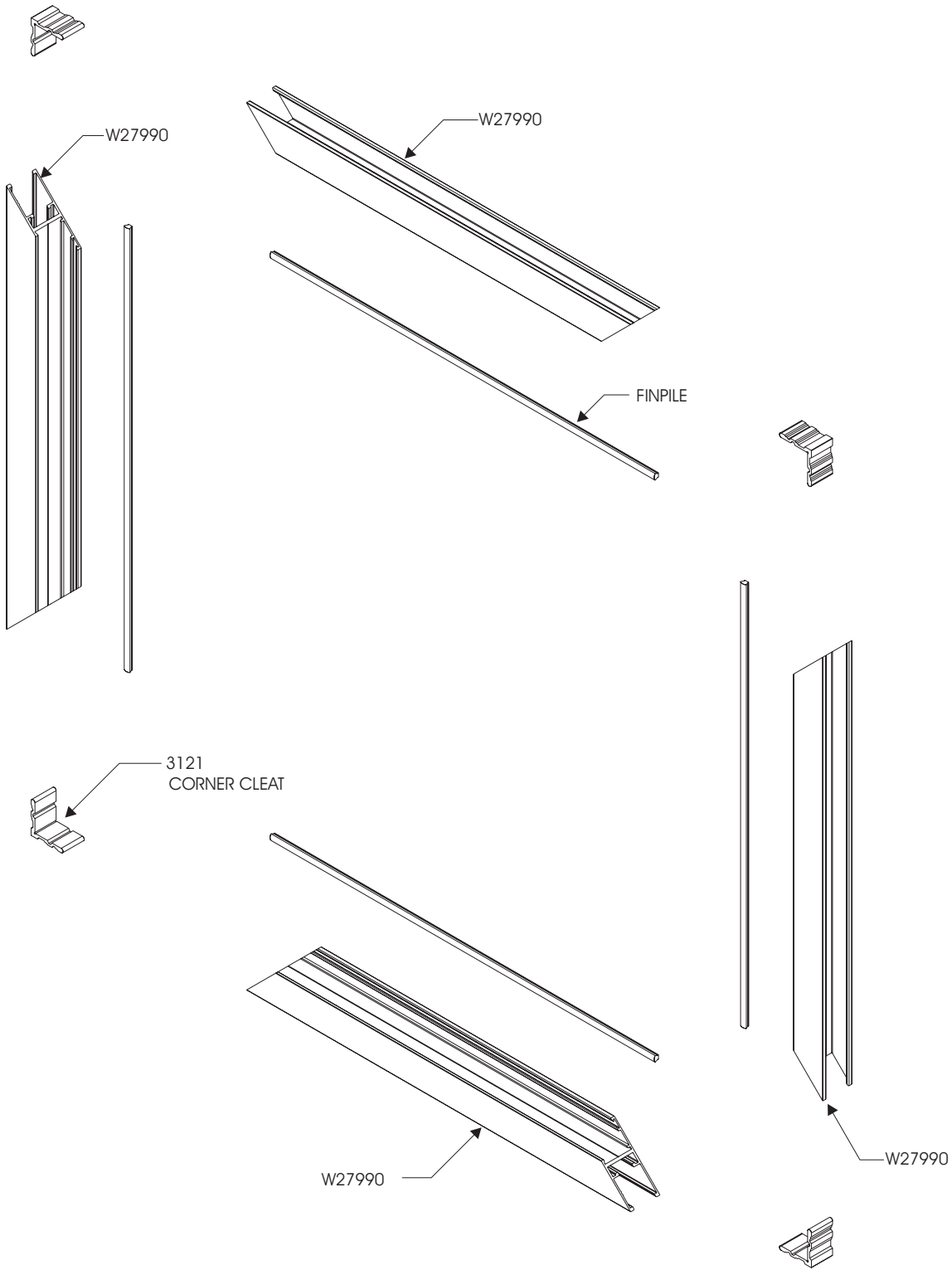

SHEERSASH 30.5 WINDOW SYSTEM SASH FRAME COMPONENT ASSEMBLY DETAIL

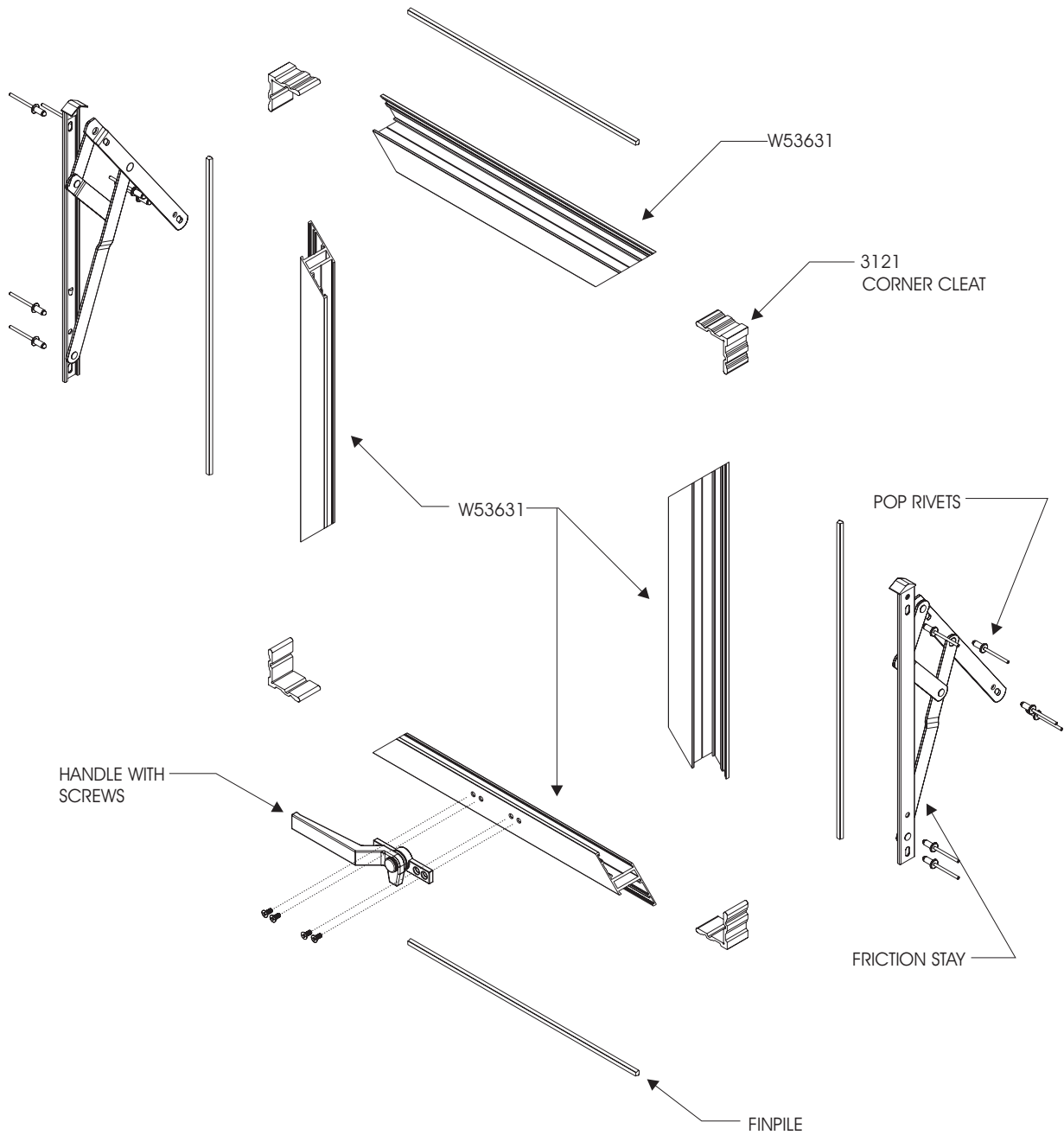

SHEERSASH 30.5 WINDOW SYSTEM
EQUAL LEG OUTER FRAME
SILL LEVEL & MACHINING DETAIL

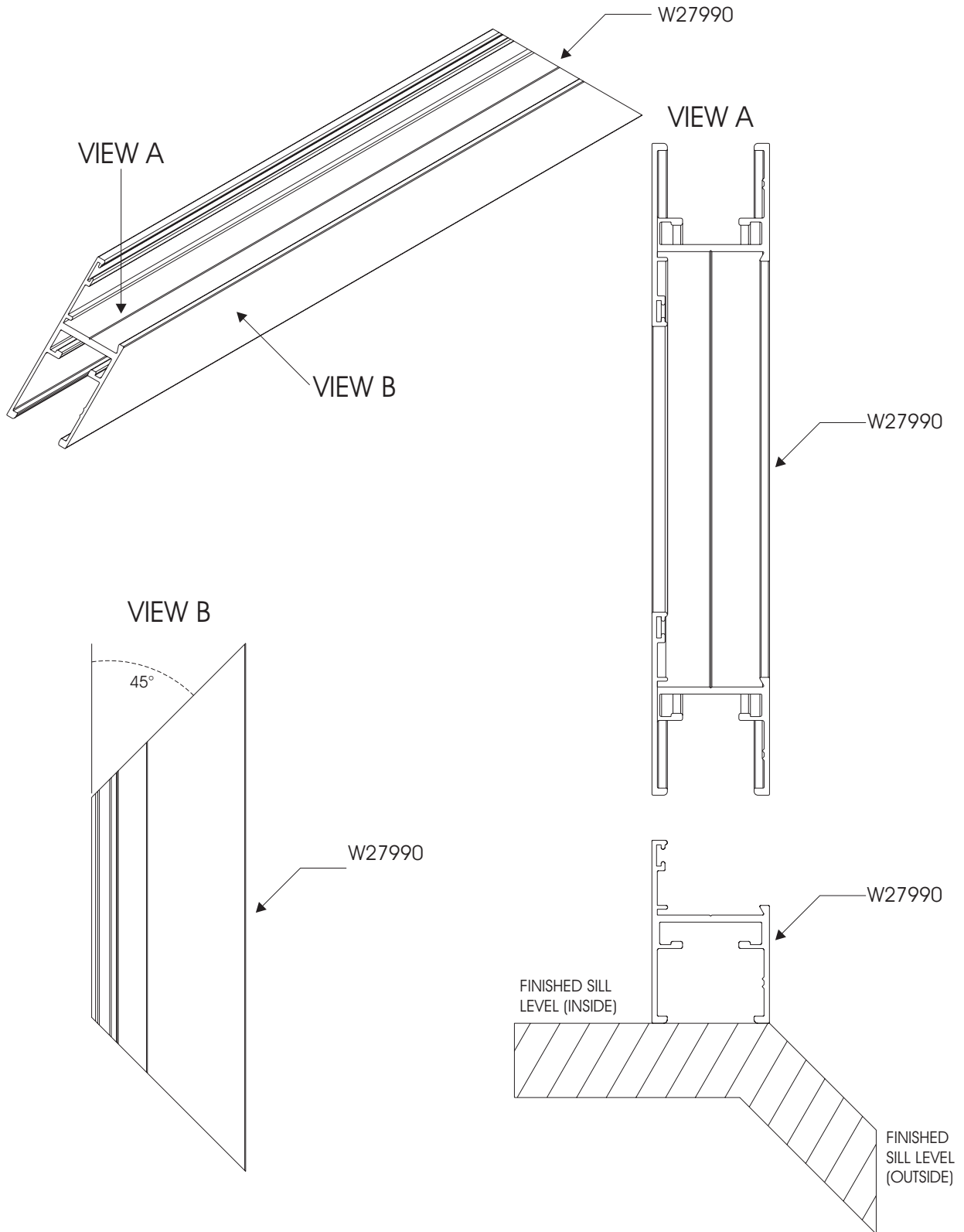

SHEERSASH 30.5 WINDOW SYSTEM
UNEQUAL LEG OUTER FRAME
SILL LEVEL & MACHINING DETAIL

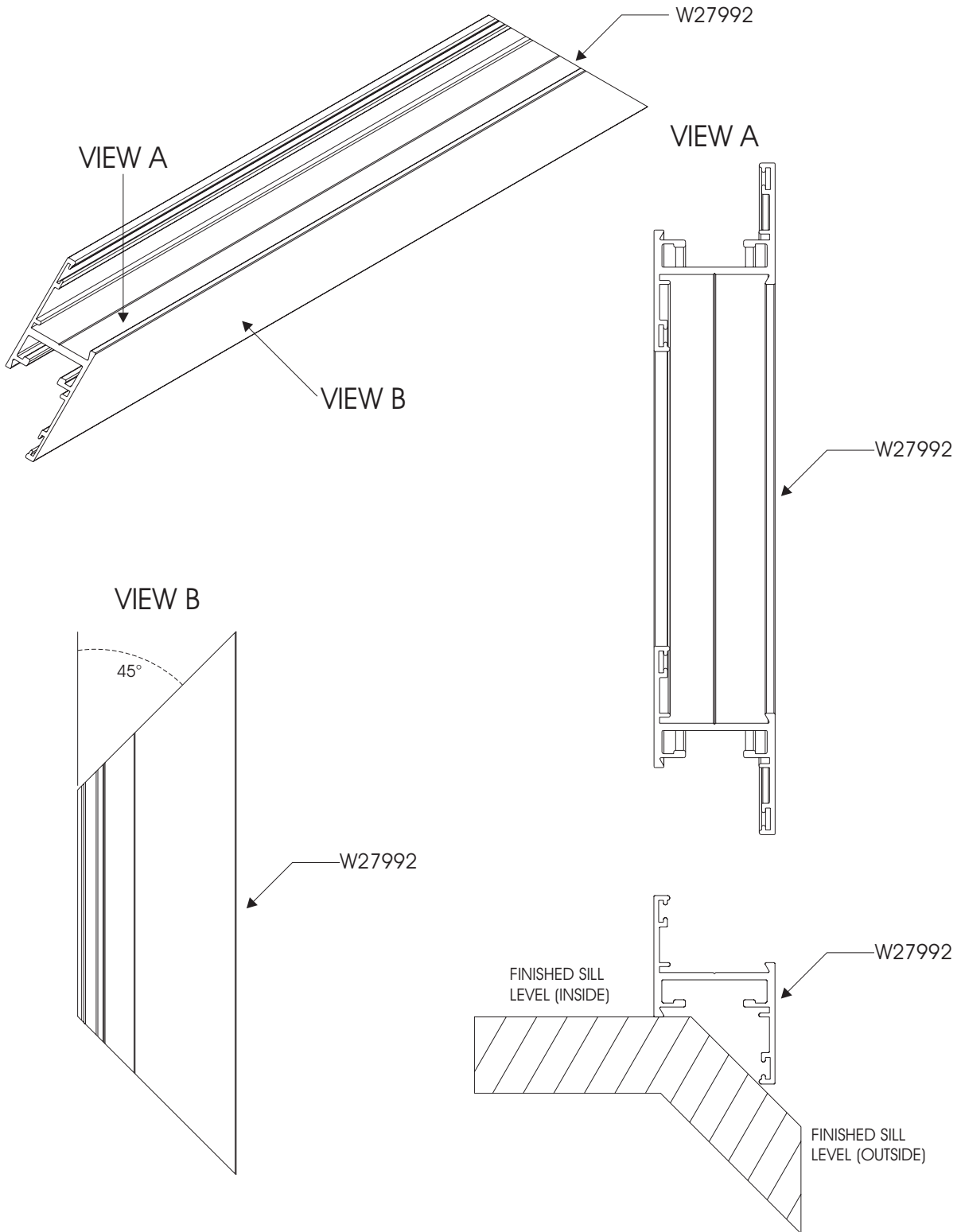

SHEERSASH 30.5 WINDOW SYSTEM
 54mm OUTER FRAME
 SILL LEVEL & MACHINING DETAIL

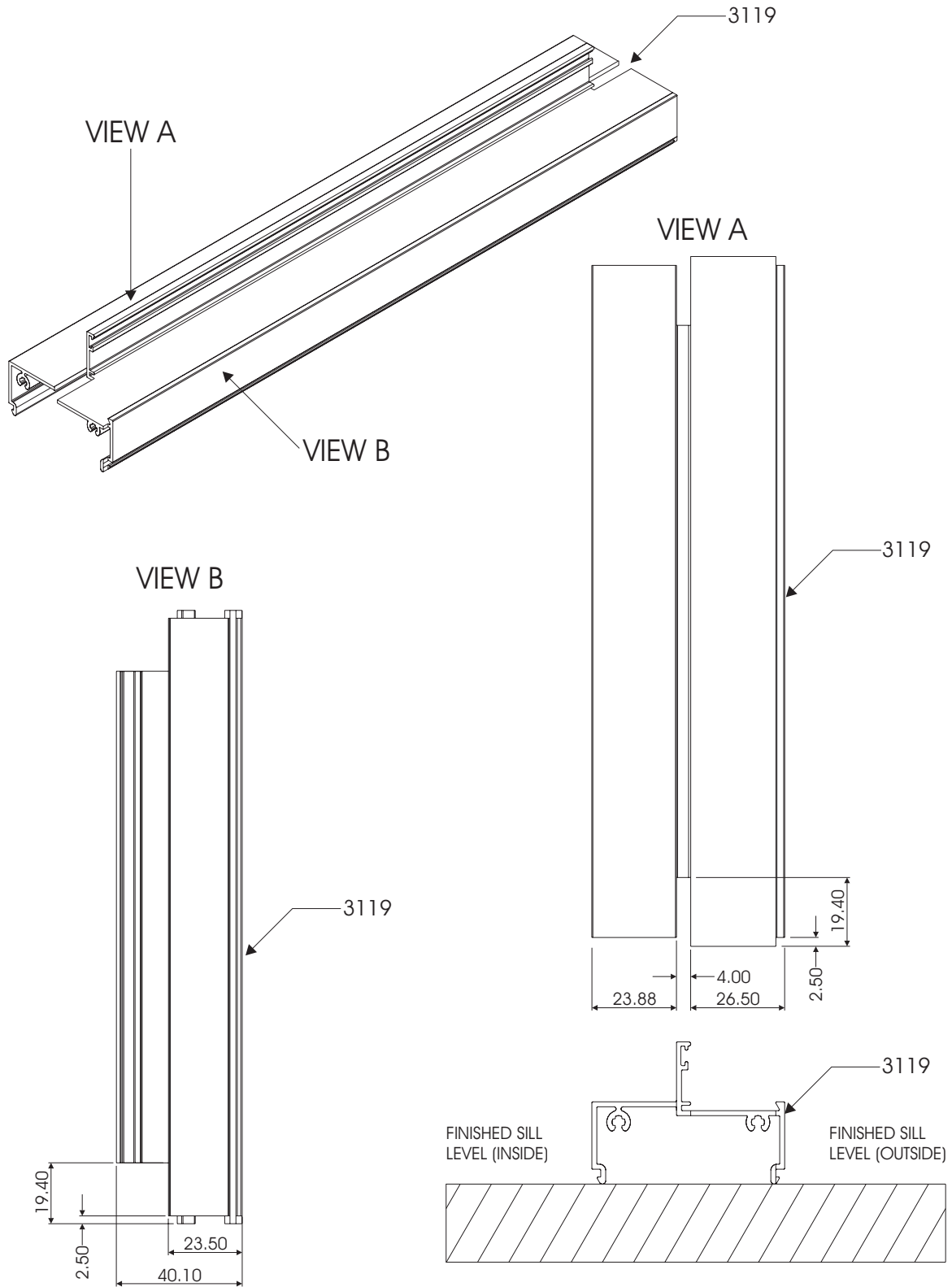

SHEERSASH 30.5 WINDOW SYSTEM
 70mm OUTER FRAME
 SILL LEVEL & MACHINING DETAIL

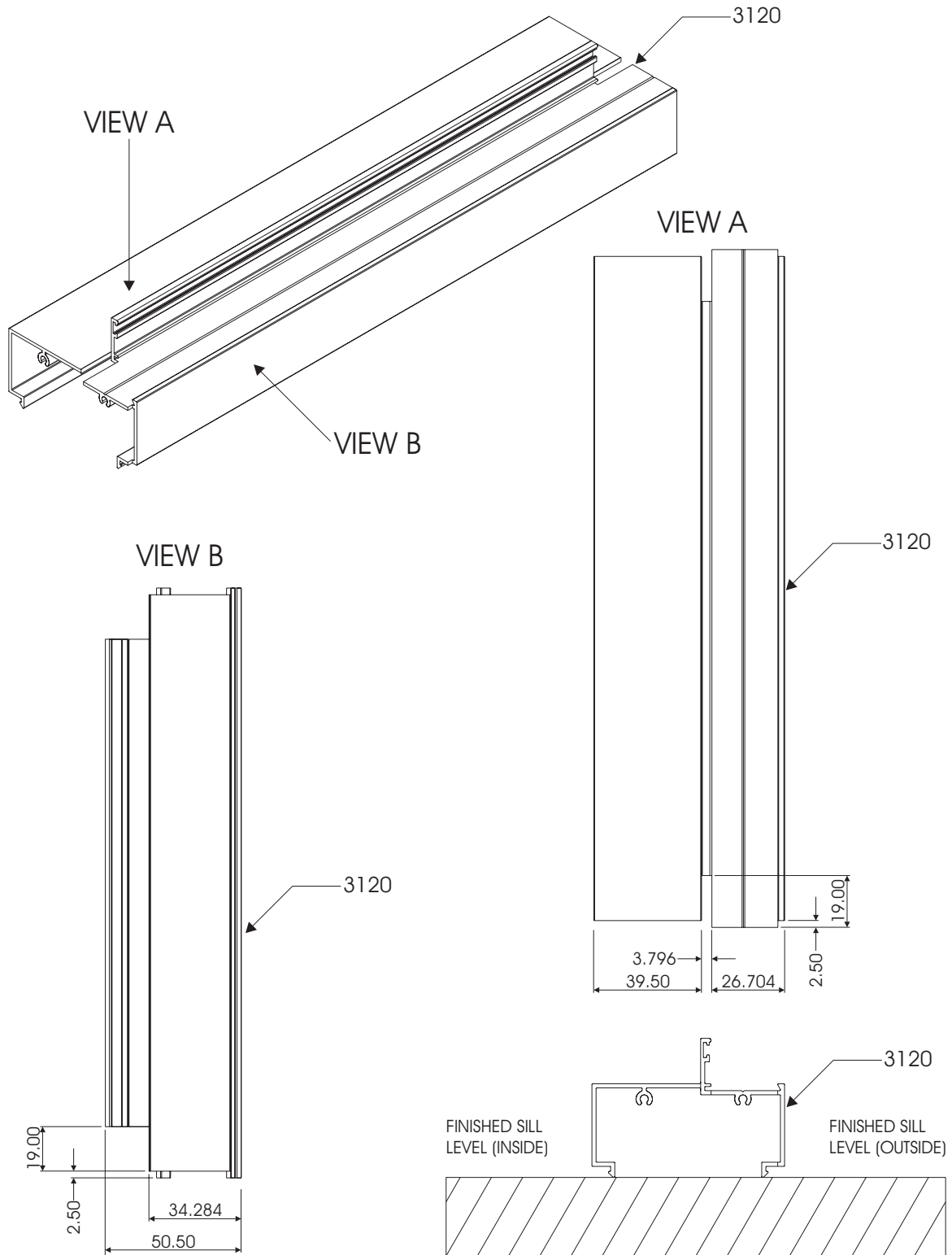

SHEERSASH 30.5 WINDOW SYSTEM
 STANDARD MULLION MACHINING
 DETAIL FOR END MILLING
 ON EQUAL LEG OUTER FRAME

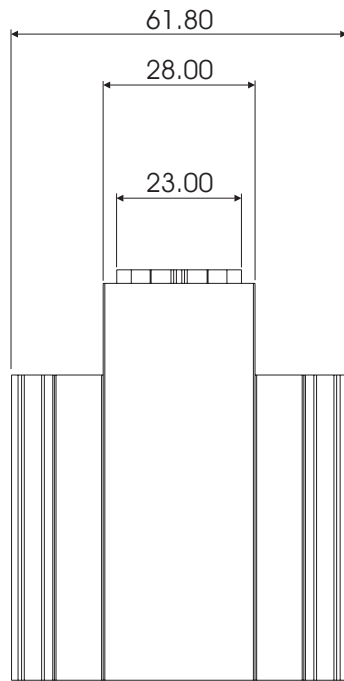
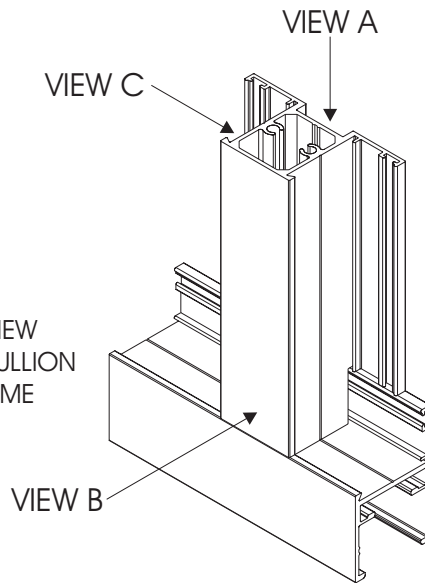
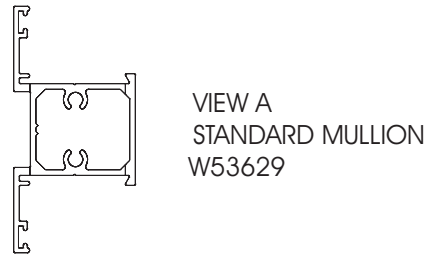
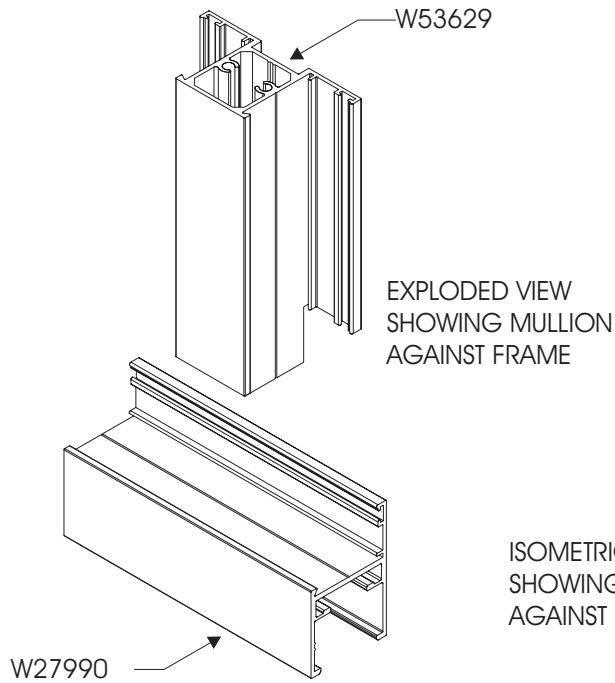

VIEW B

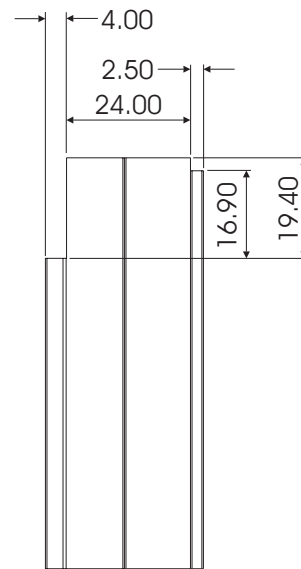

VIEW C

Disclaimer: The right to make alterations is reserved
 © 2010 Sheerline, All Rights Reserved

SHEERSASH 30.5 WINDOW SYSTEM
 STANDARD MULLION MACHINING
 DETAIL FOR END MILLING
 ON UNEQUAL LEG OUTER FRAME

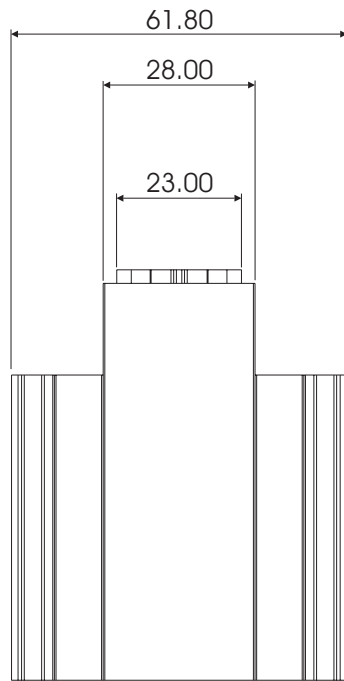
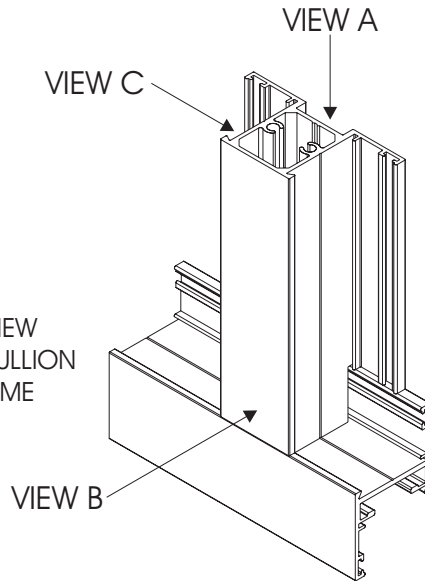
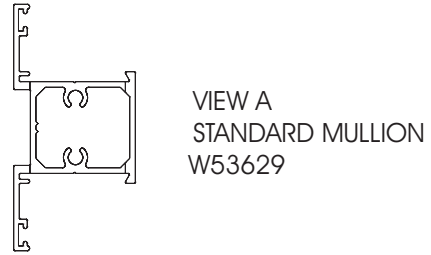
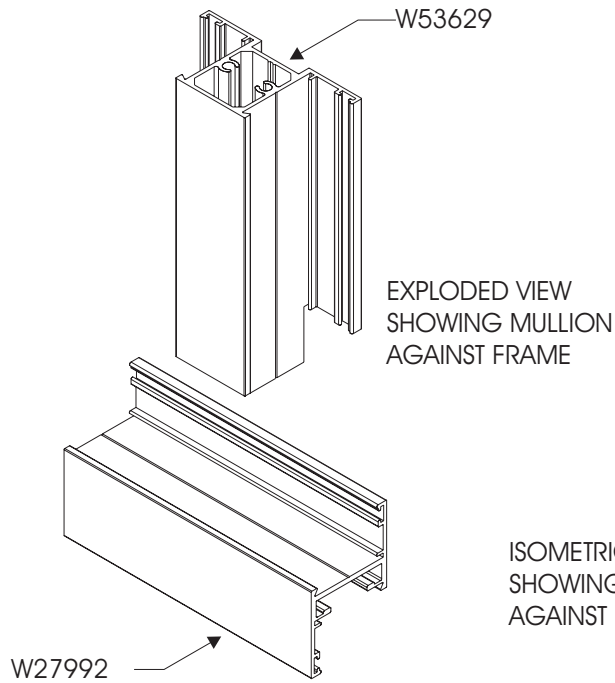

VIEW B

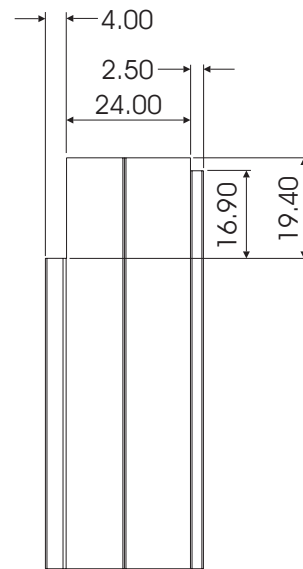

VIEW C

Disclaimer: The right to make alterations is reserved
 © 2010 Sheerline, All Rights Reserved

SHEERSASH 30.5 WINDOW SYSTEM
 STANDARD MULLION MACHINING
 DETAIL FOR END MILLING
 ON 54mm OUTER FRAME

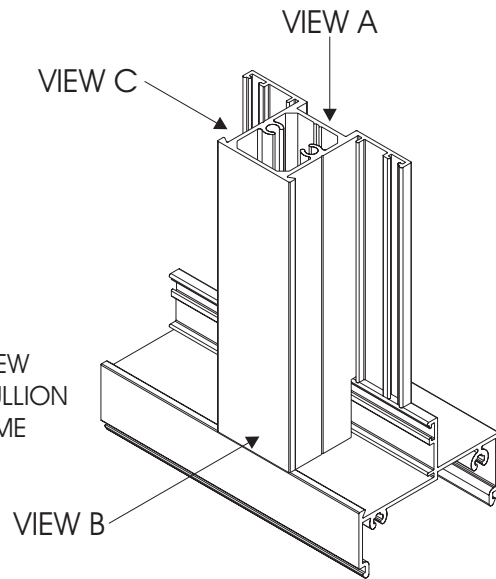
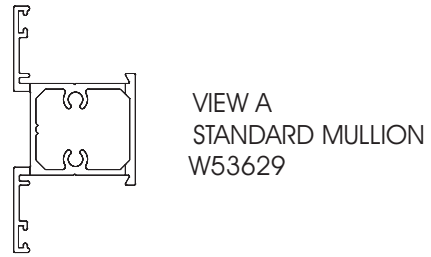
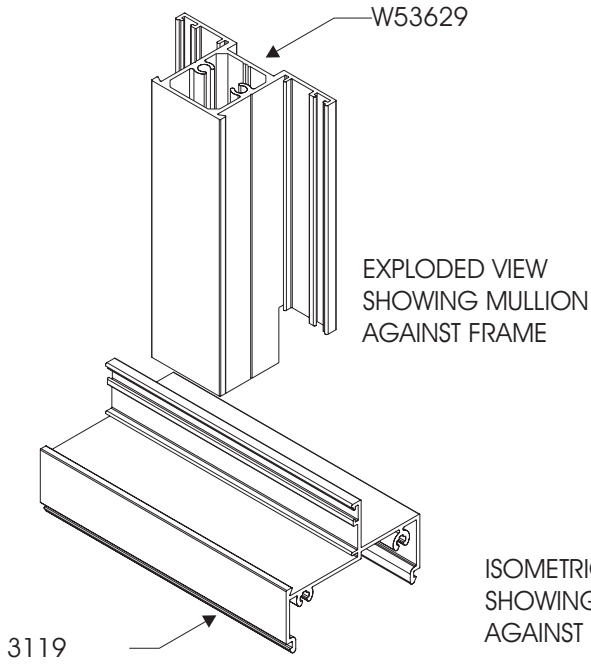

ISOMETRIC VIEW
 SHOWING MULLION
 AGAINST FRAME

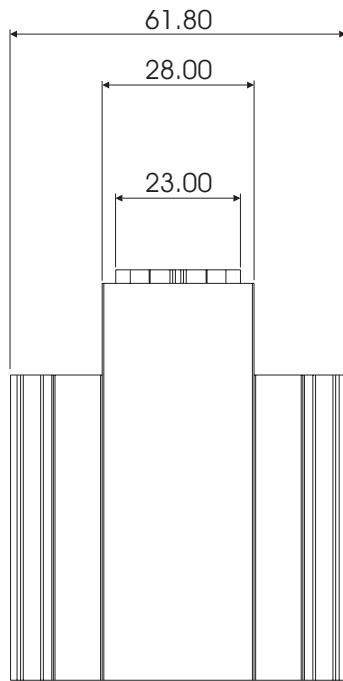

VIEW B

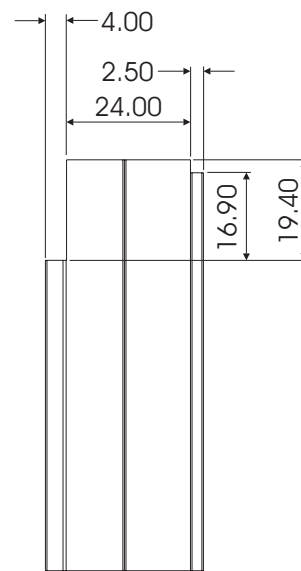

VIEW C

SHEERSASH 30.5 WINDOW SYSTEM
 STANDARD MULLION MACHINING
 DETAIL FOR END MILLING
 ON 70mm OUTER FRAME

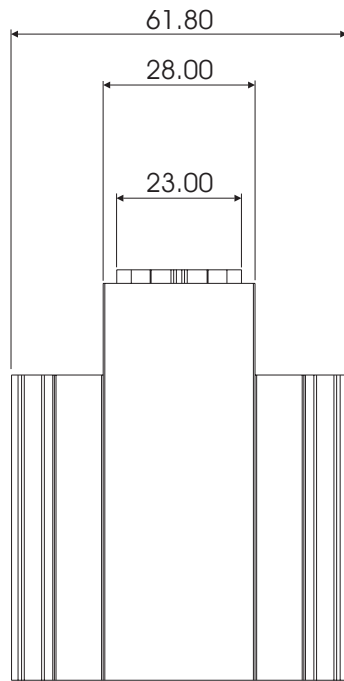
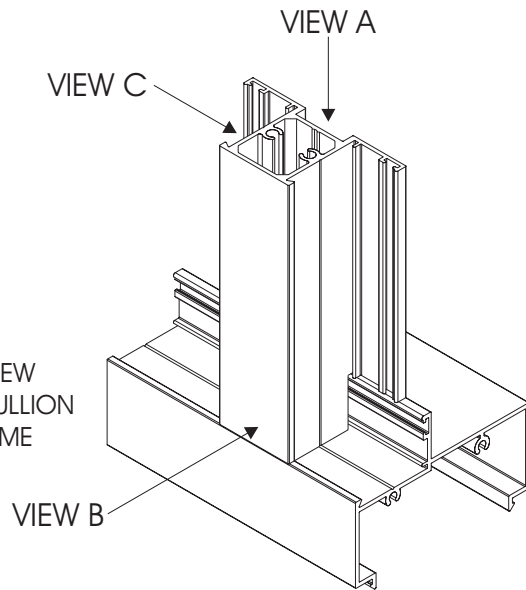
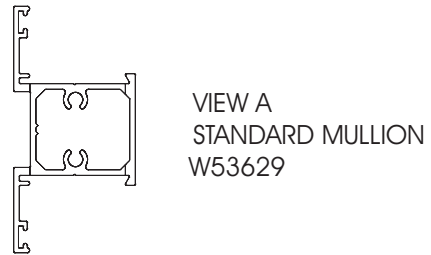
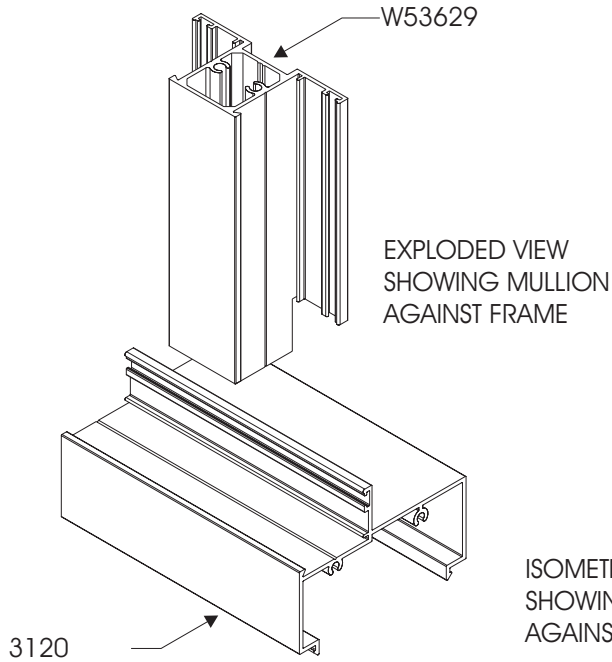

VIEW B

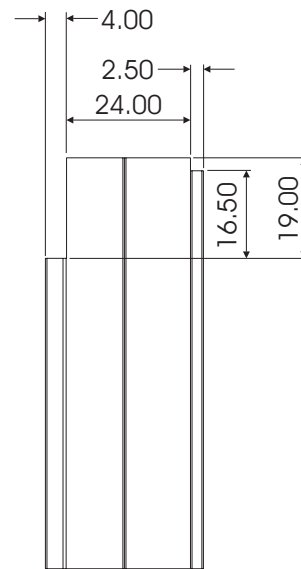

VIEW C

SHEERSASH 30.5 WINDOW SYSTEM
 STANDARD MULLION MACHINING
 DETAIL FOR END MILLING
 ON LITE EQUAL LEG OUTER FRAME

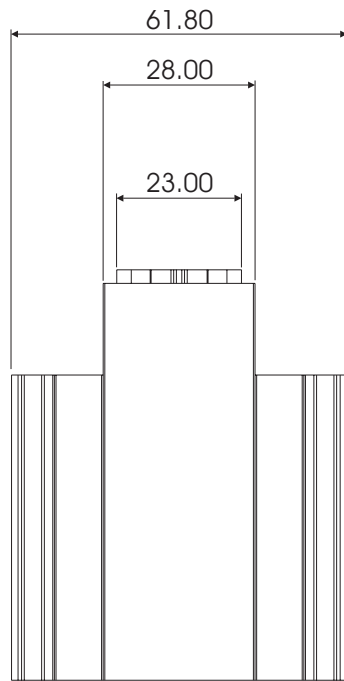
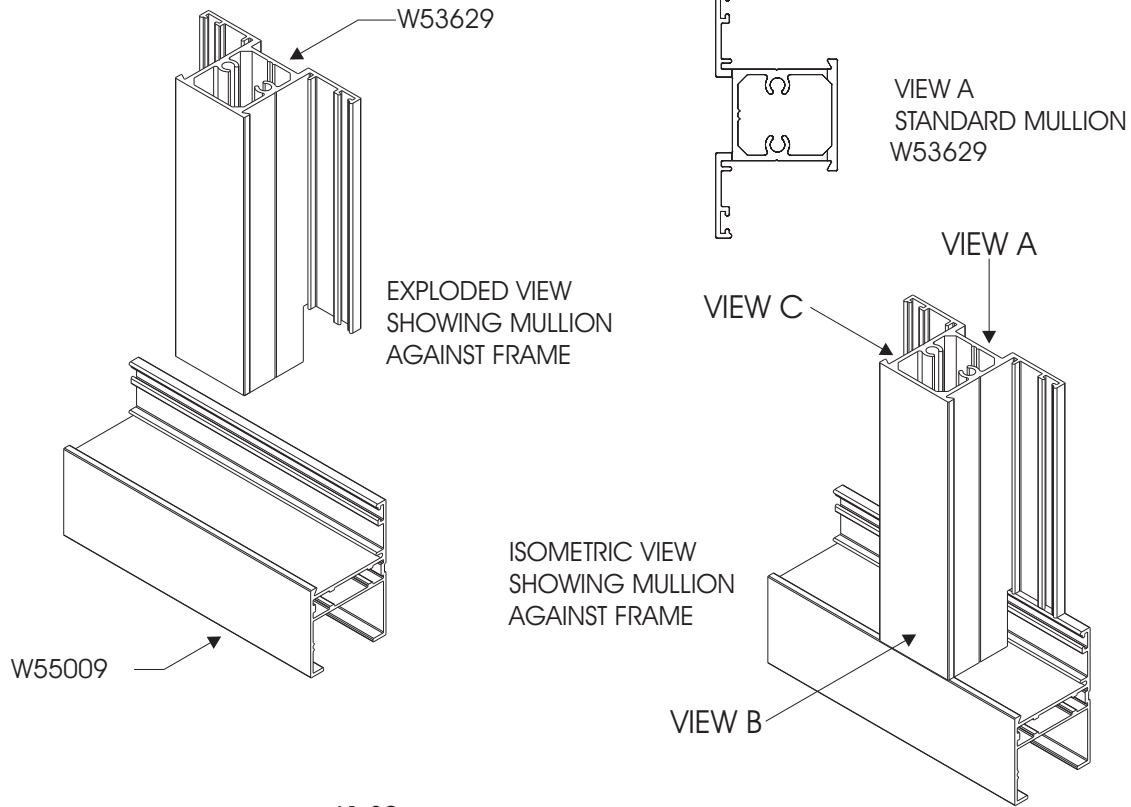

VIEW B

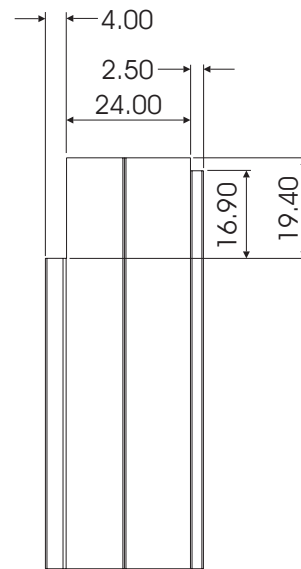

VIEW C

Disclaimer: The right to make alterations is reserved
 © 2010 Sheerline, All Rights Reserved

SHEERSASH 30.5 WINDOW SYSTEM
 STANDARD TRANSOM WITH W/B
 MACHINING DETAIL FOR END MILLING
 ON EQUAL LEG OUTER FRAME

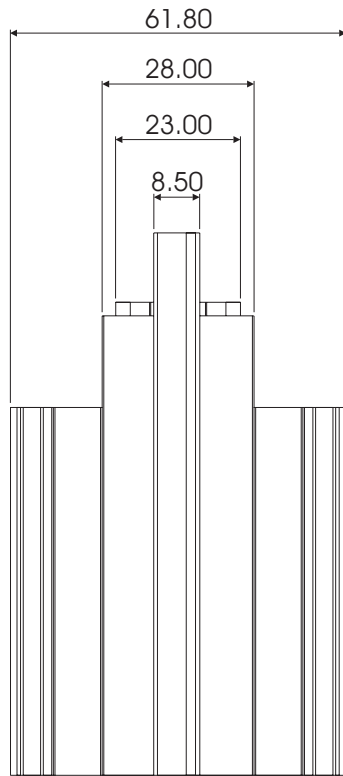
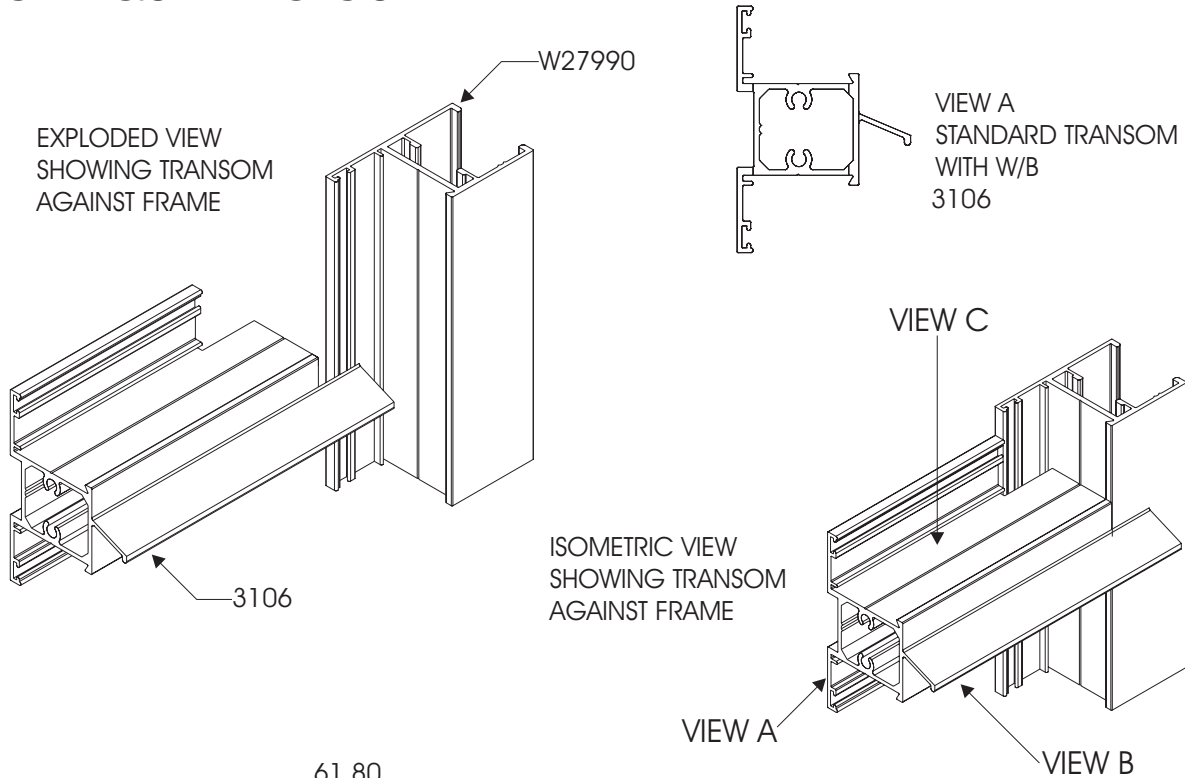

VIEW B

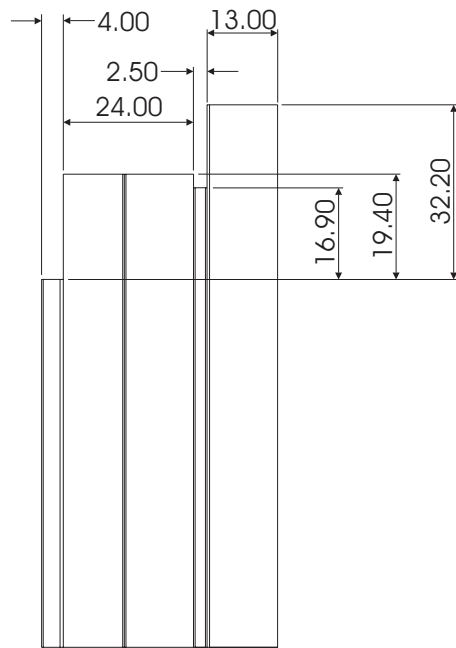

VIEW C

Disclaimer: The right to make alterations is reserved
 © 2010 Sheerline, All Rights Reserved

SHEERSASH 30.5 WINDOW SYSTEM
 STANDARD TRANSOM WITH W/B
 MACHINING DETAIL FOR END MILLING
 ON UNEQUAL LEG OUTER FRAME

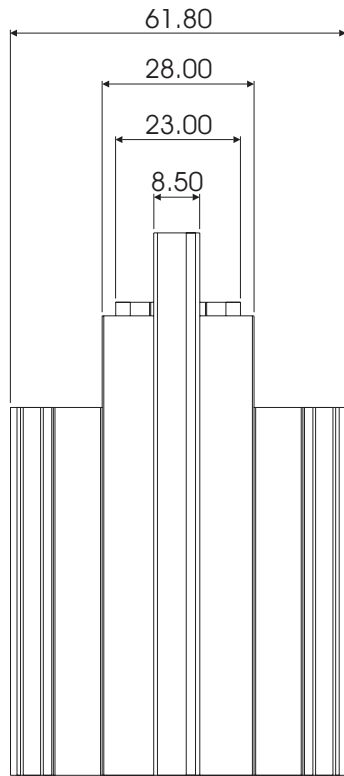
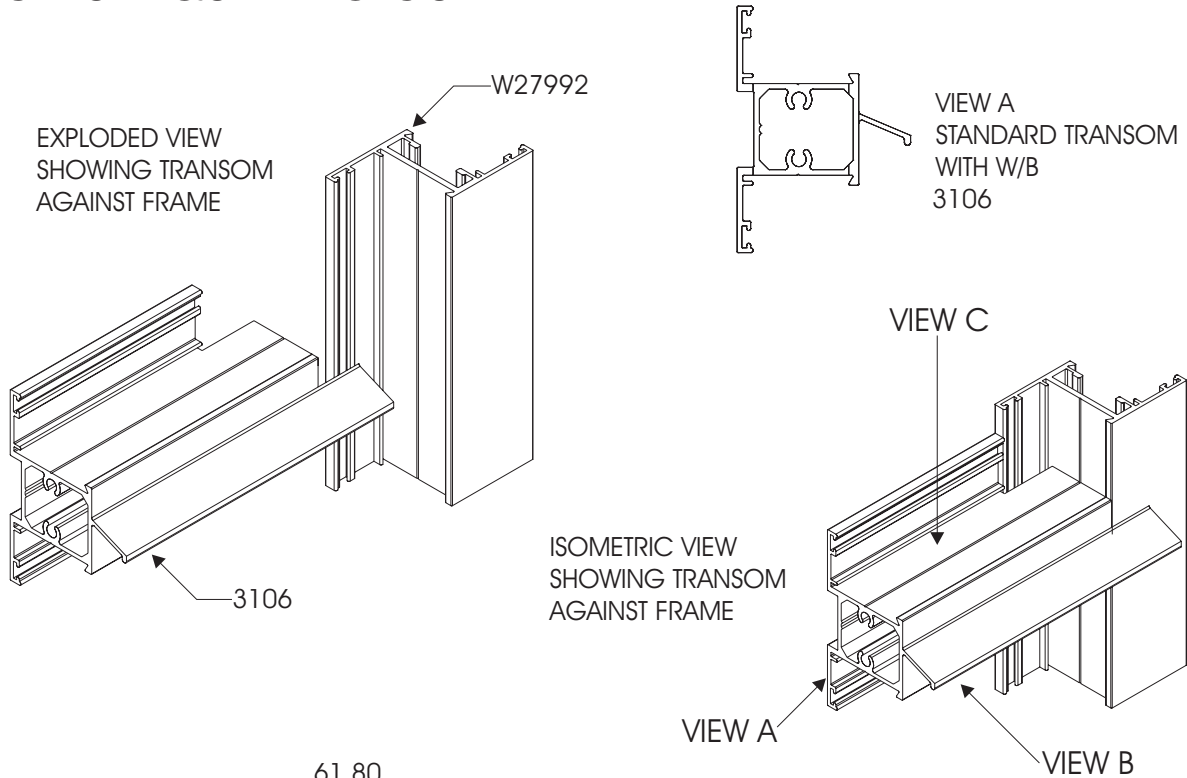

VIEW B

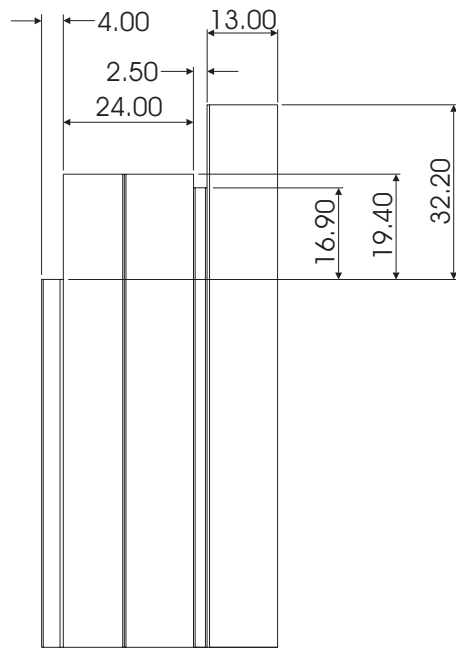

VIEW C

Disclaimer: The right to make alterations is reserved
 © 2010 Sheerline, All Rights Reserved

SHEERSASH 30.5 WINDOW SYSTEM
 STANDARD TRANSOM WITH W/B
 MACHINING DETAIL FOR END MILLING
 ON 54mm OUTER FRAME

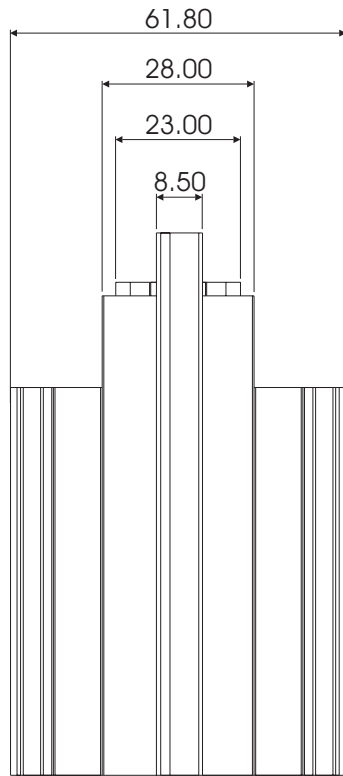
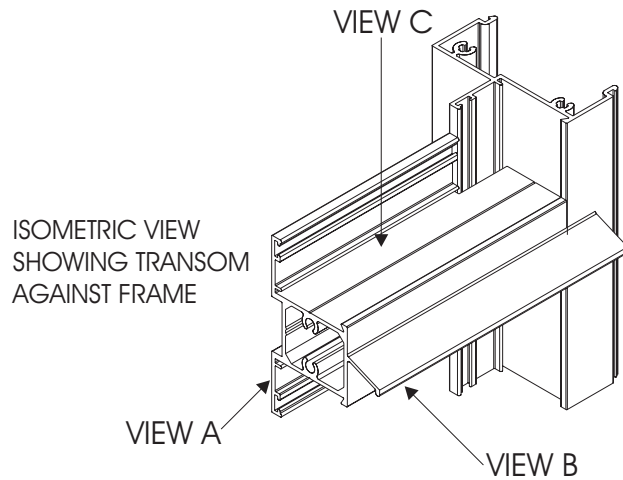
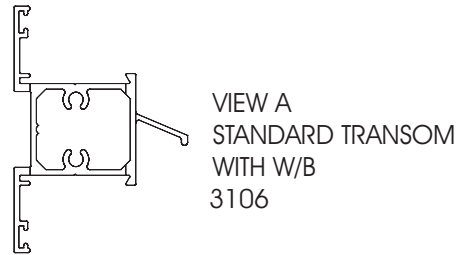
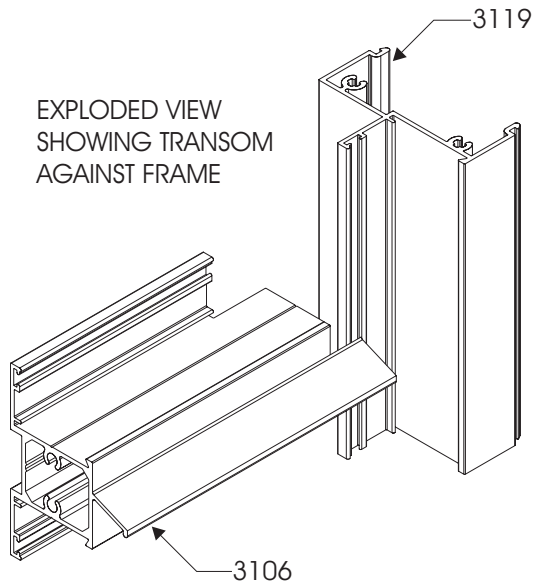

VIEW B

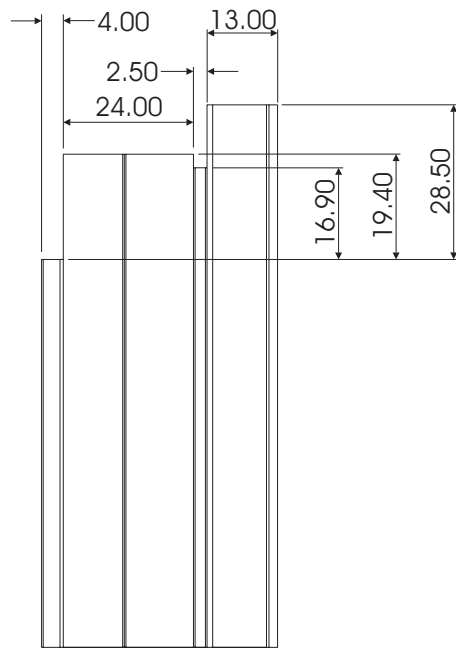

VIEW C

Disclaimer: The right to make alterations is reserved
 © 2010 Sheerline, All Rights Reserved

SHEERSASH 30.5 WINDOW SYSTEM
 STANDARD TRANSOM WITH W/B
 MACHINING DETAIL FOR END MILLING
 ON 70mm OUTER FRAME

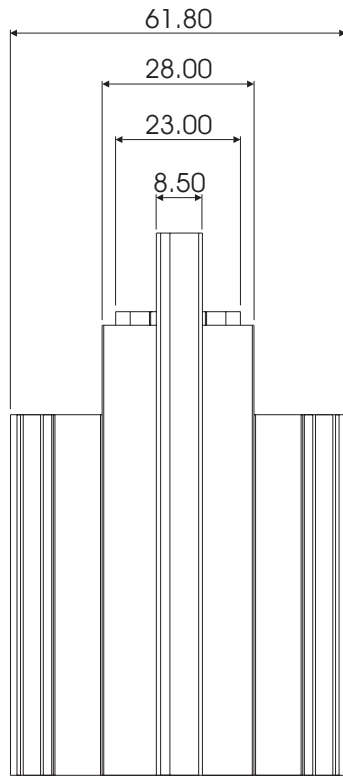
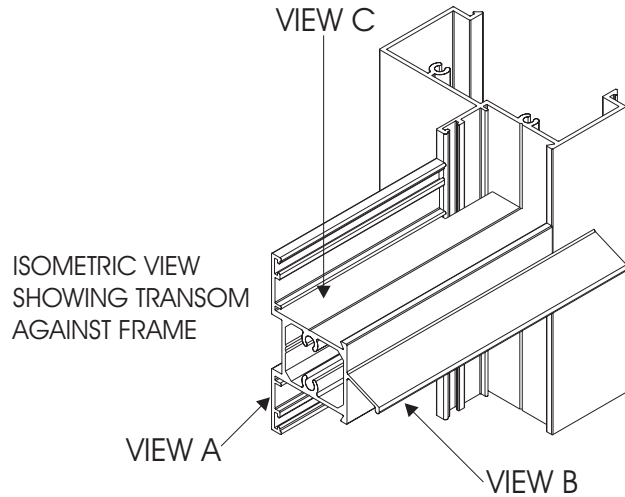
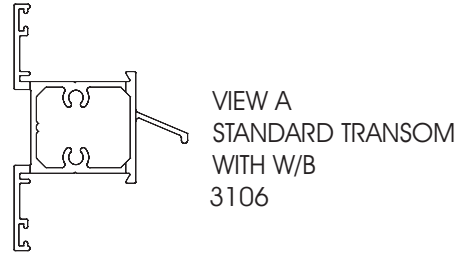
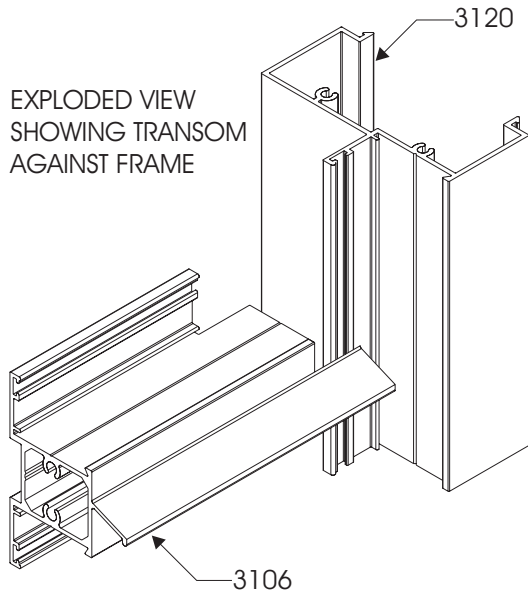

VIEW B

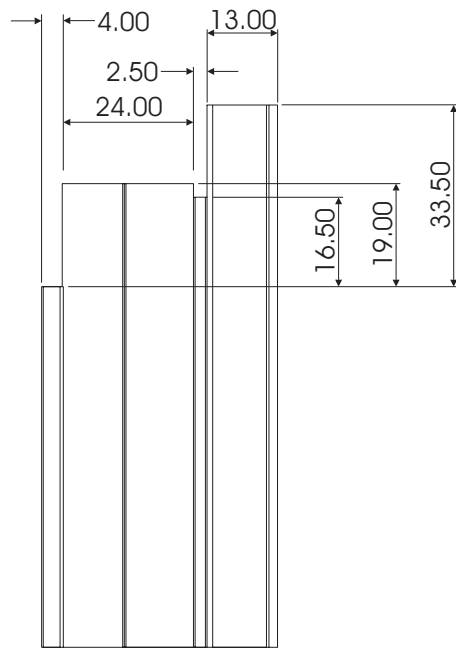

VIEW C

Disclaimer: The right to make alterations is reserved
 © 2010 Sheerline, All Rights Reserved

SHEERSASH 30.5 WINDOW SYSTEM
 STANDARD TRANSOM WITH W/B
 MACHINING DETAIL FOR END MILLING
 ON LITE EQUAL LEG OUTER FRAME

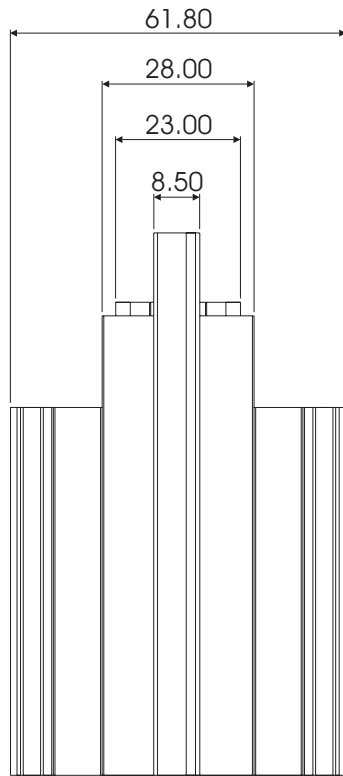
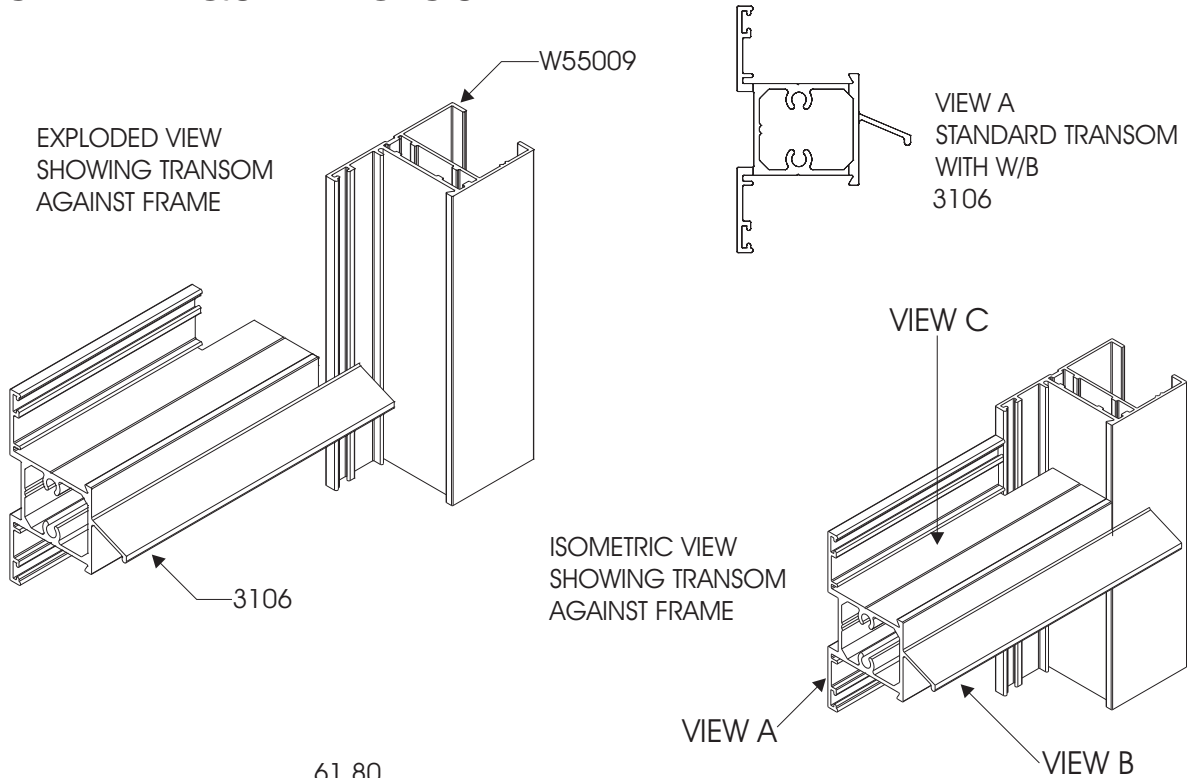

VIEW B

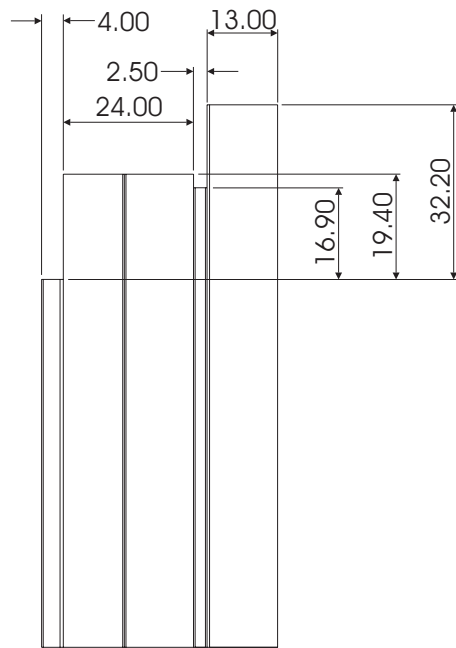

VIEW C

Disclaimer: The right to make alterations is reserved
 © 2010 Sheerline, All Rights Reserved

SHEERSASH 30.5 WINDOW SYSTEM
 54mm MULLION MACHINING
 DETAIL FOR END MILLING
 ON EQUAL LEG OUTER FRAME

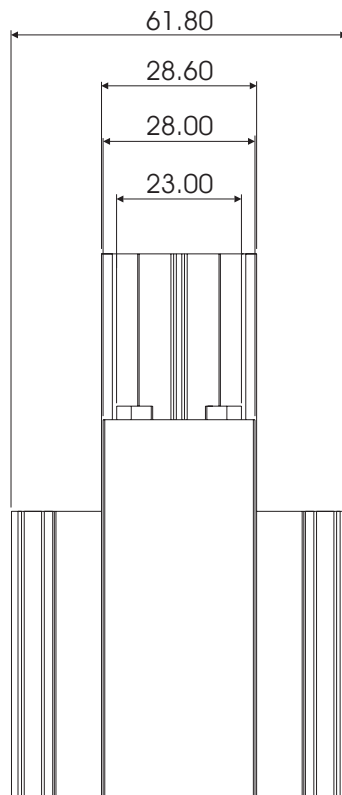
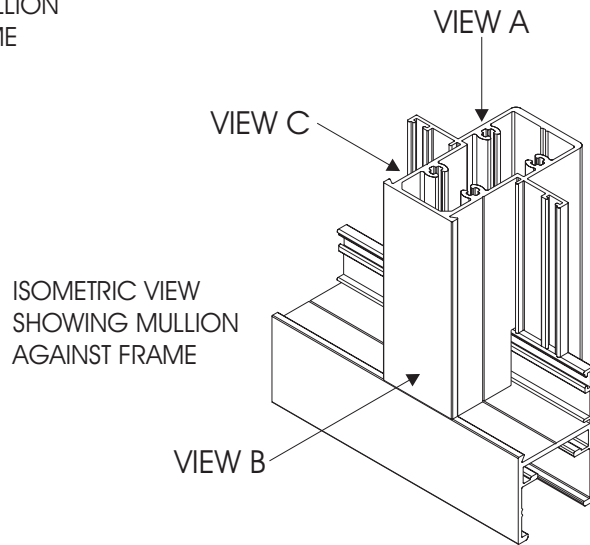
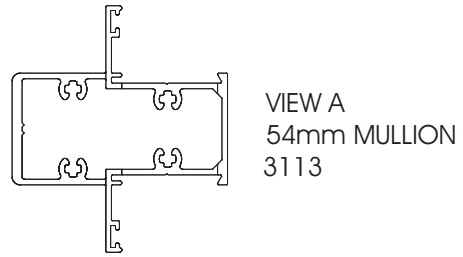
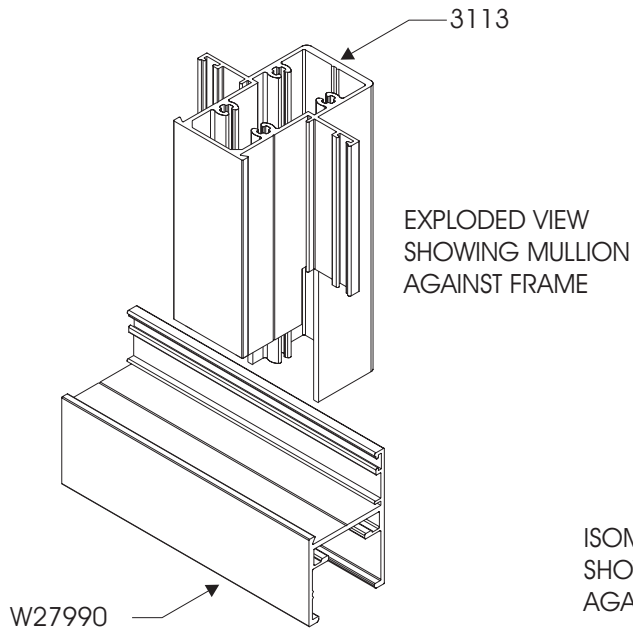

VIEW B

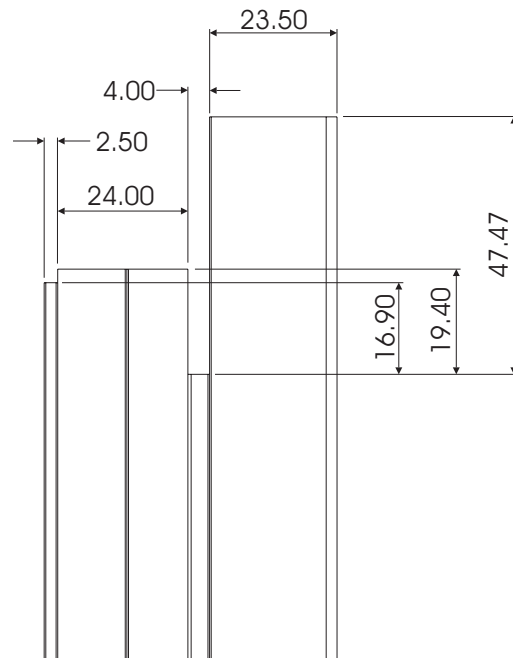

VIEW C

Disclaimer: The right to make alterations is reserved
 © 2010 Sheerline, All Rights Reserved

SHEERSASH 30.5 WINDOW SYSTEM
 54mm MULLION MACHINING
 DETAIL FOR END MILLING
 ON UNEQUAL LEG OUTER FRAME

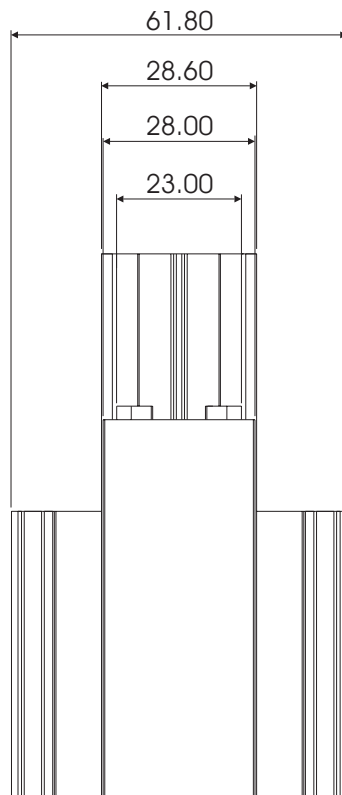
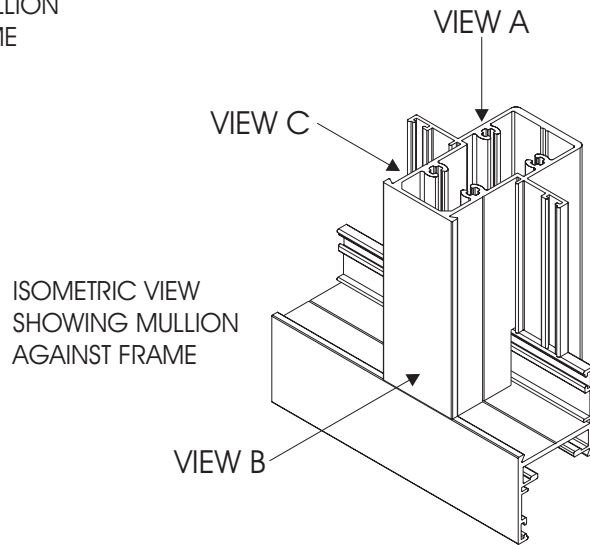
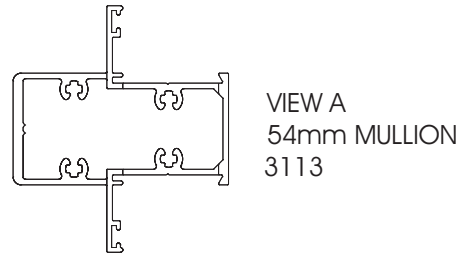
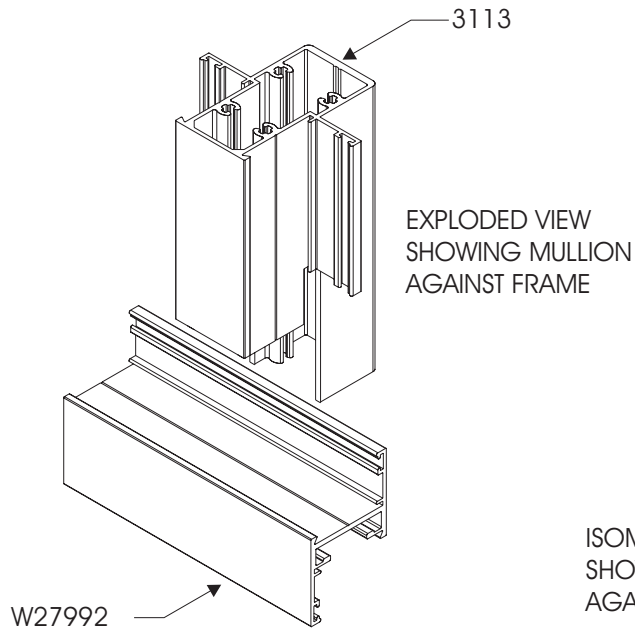

VIEW B

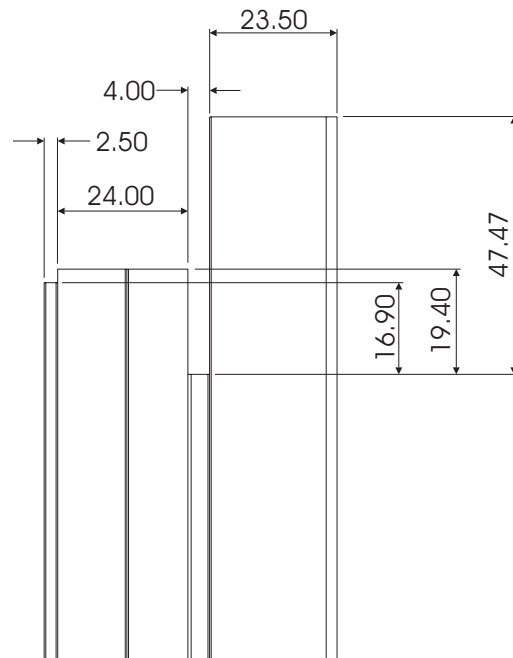

VIEW C

Disclaimer: The right to make alterations is reserved
 © 2010 Sheerline, All Rights Reserved

SHEERSASH 30.5 WINDOW SYSTEM
 54mm MULLION MACHINING
 DETAIL FOR END MILLING
 ON 54mm OUTER FRAME

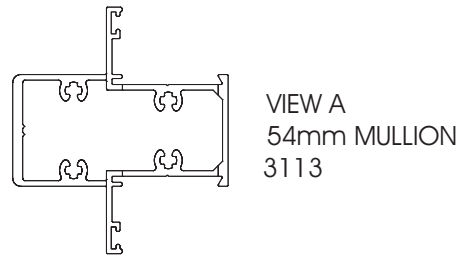
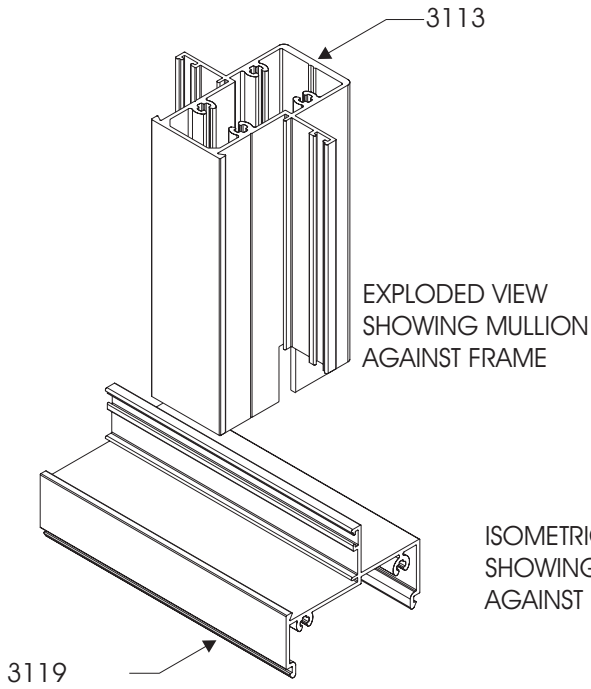

ISOMETRIC VIEW
 SHOWING MULLION
 AGAINST FRAME

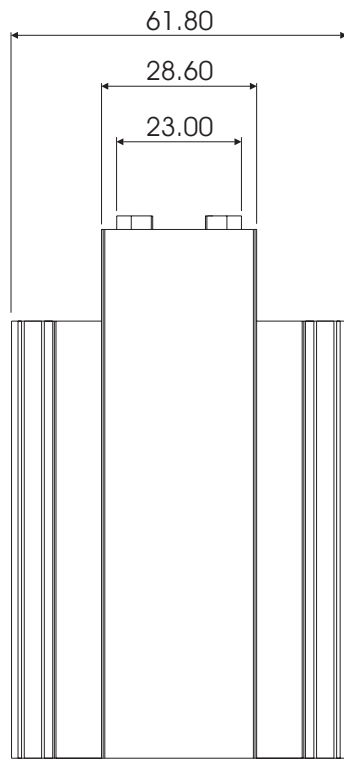
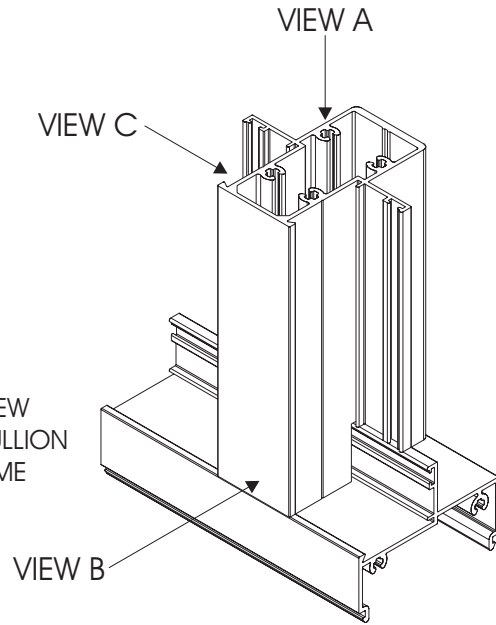

VIEW B

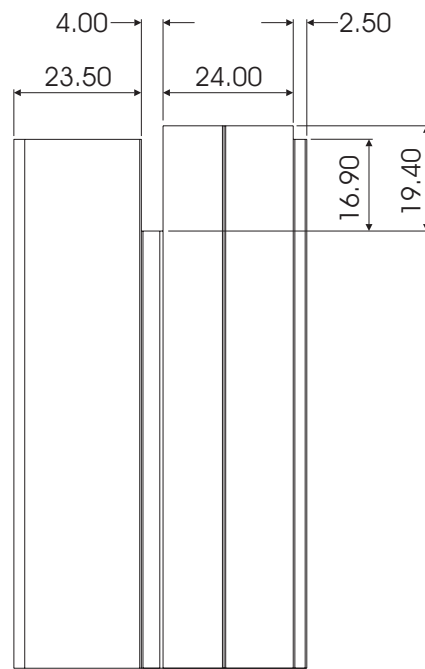

VIEW C

SHEERSASH 30.5 WINDOW SYSTEM
 54mm MULLION MACHINING
 DETAIL FOR END MILLING
 ON 70mm OUTER FRAME

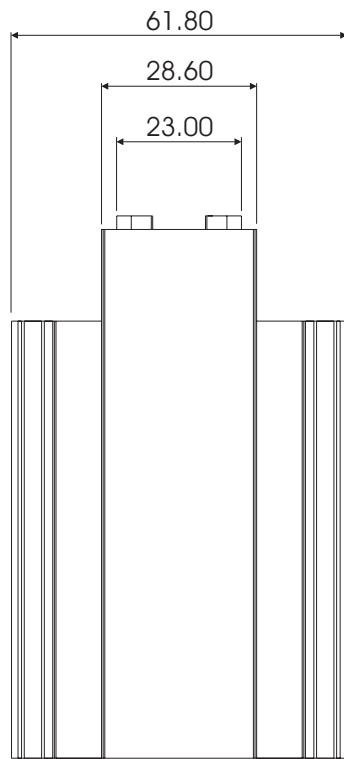
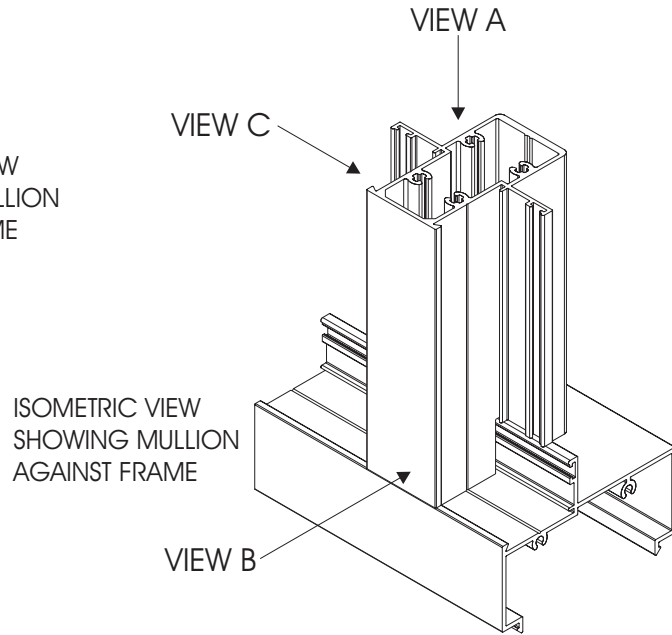
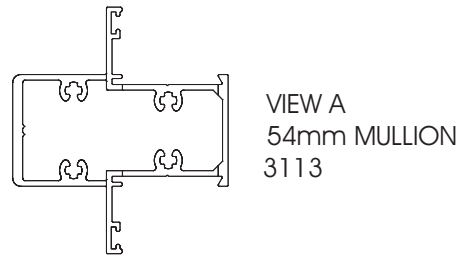
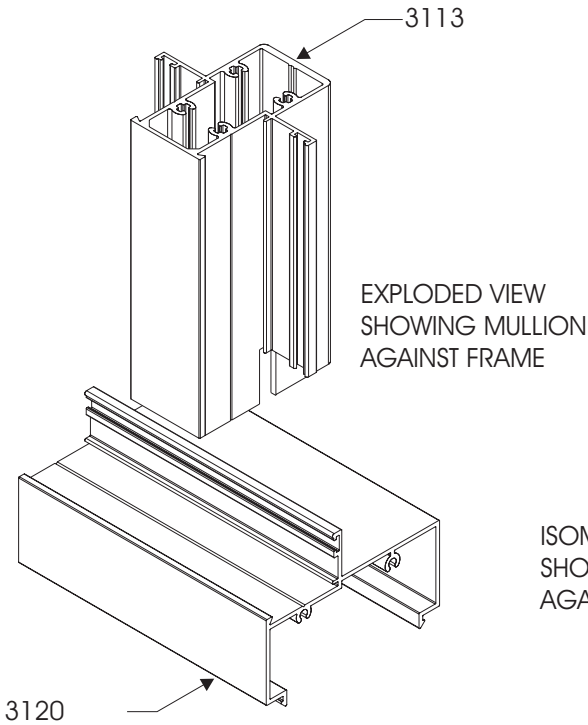

VIEW B

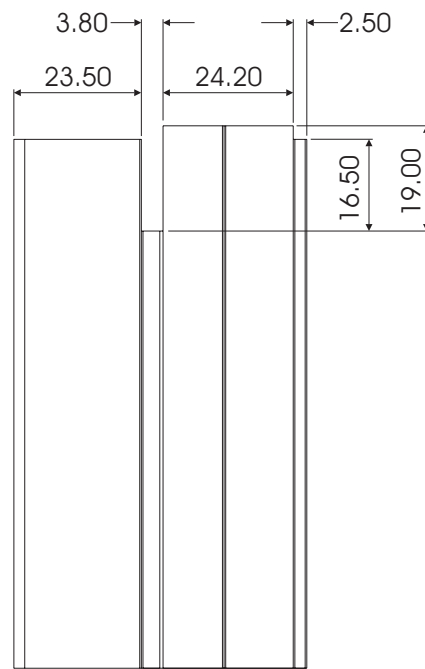

VIEW C

Disclaimer: The right to make alterations is reserved
 © 2010 Sheerline, All Rights Reserved

SHEERSASH 30.5 WINDOW SYSTEM
 54mm MULLION MACHINING
 DETAIL FOR END MILLING
 ON LITE EQUAL LEG OUTER FRAME

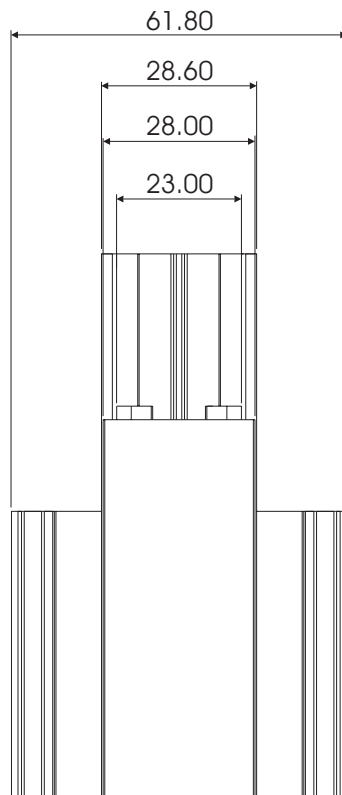
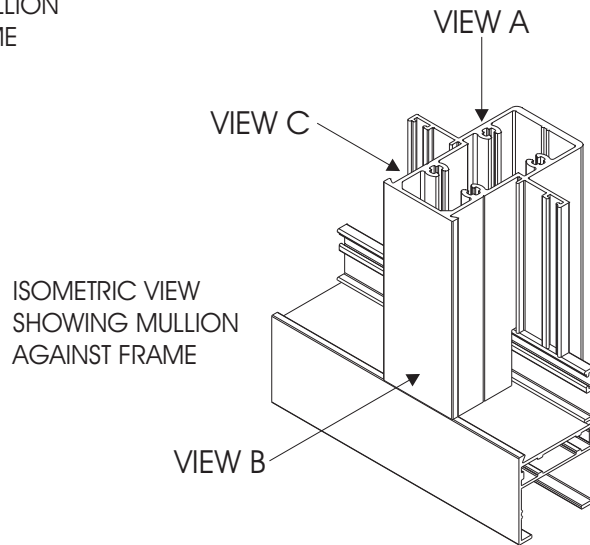
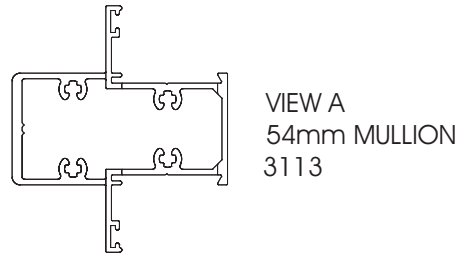
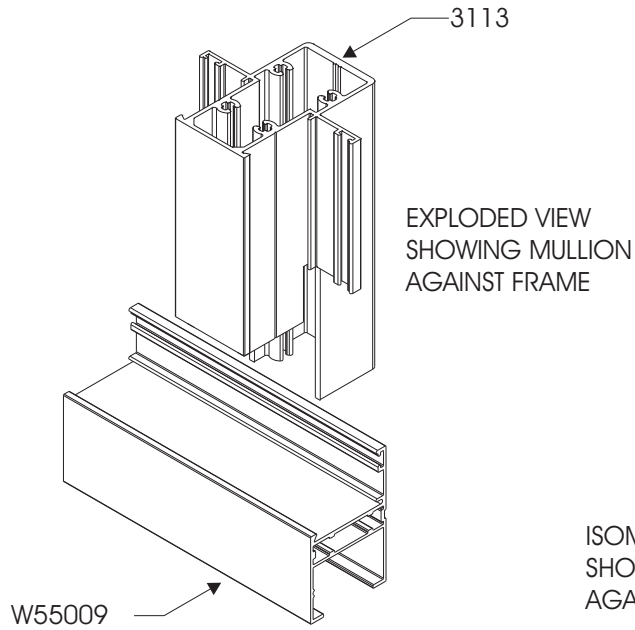

VIEW B

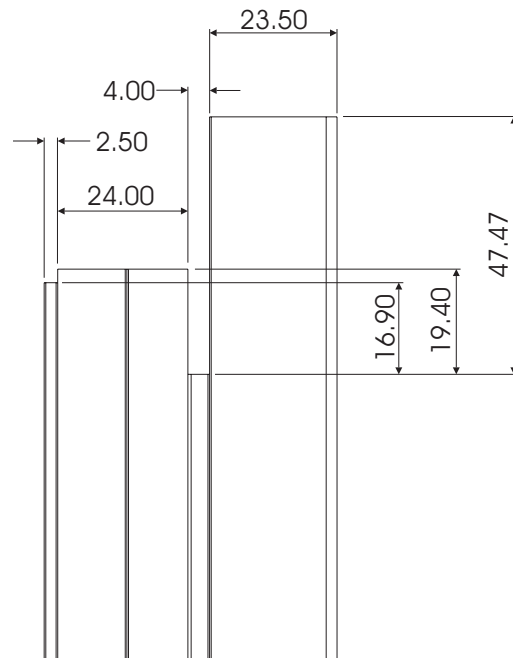

VIEW C

Disclaimer: The right to make alterations is reserved
 © 2010 Sheerline, All Rights Reserved

SHEERSASH 30.5 WINDOW SYSTEM
 70mm MULLION MACHINING
 DETAIL FOR END MILLING
 ON EQUAL LEG OUTER FRAME

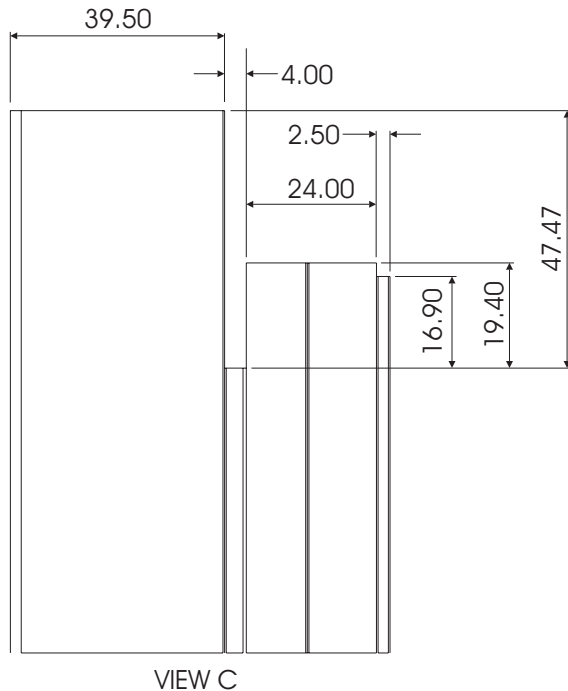
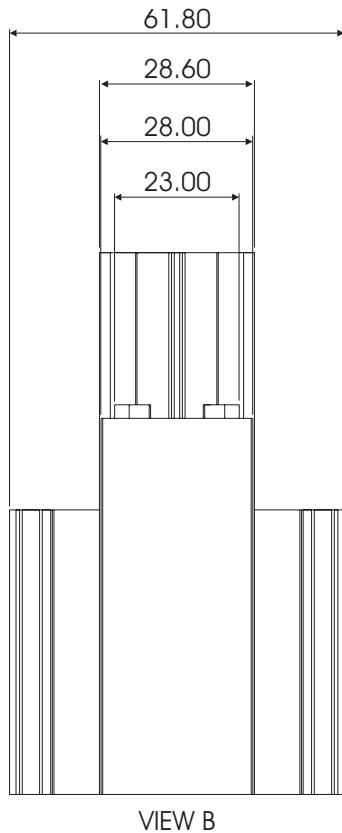
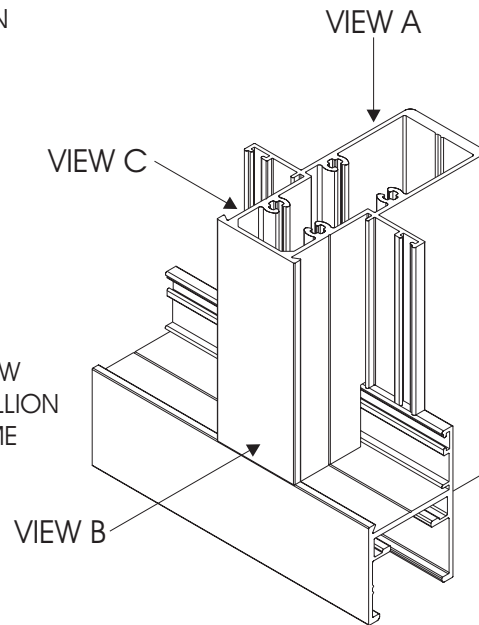
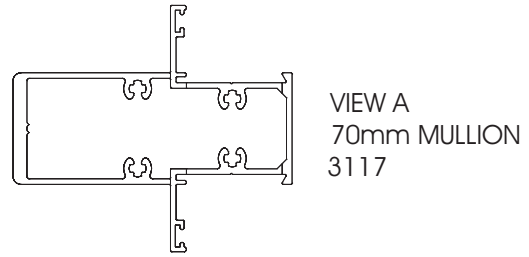
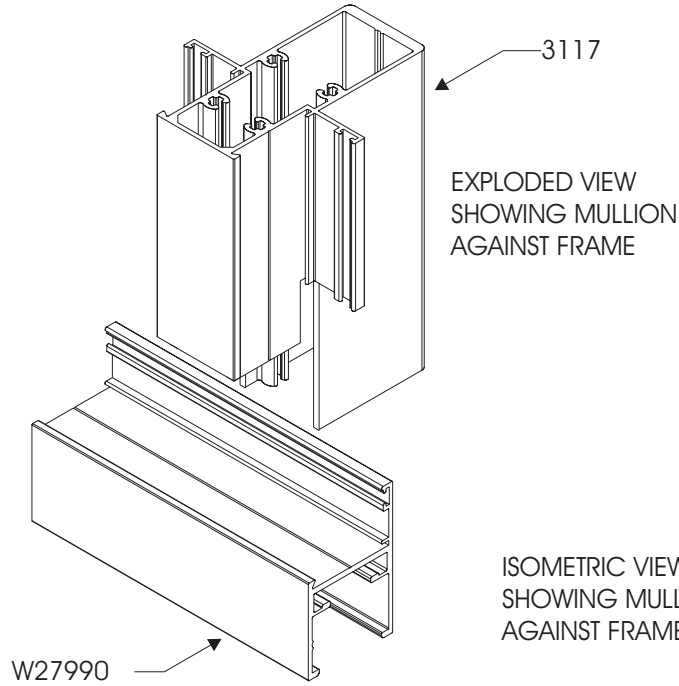

Disclaimer: The right to make alterations is reserved
 © 2010 Sheerline, All Rights Reserved

SHEERSASH 30.5 WINDOW SYSTEM
 70mm MULLION MACHINING
 DETAIL FOR END MILLING
 ON UNEQUAL LEG OUTER FRAME

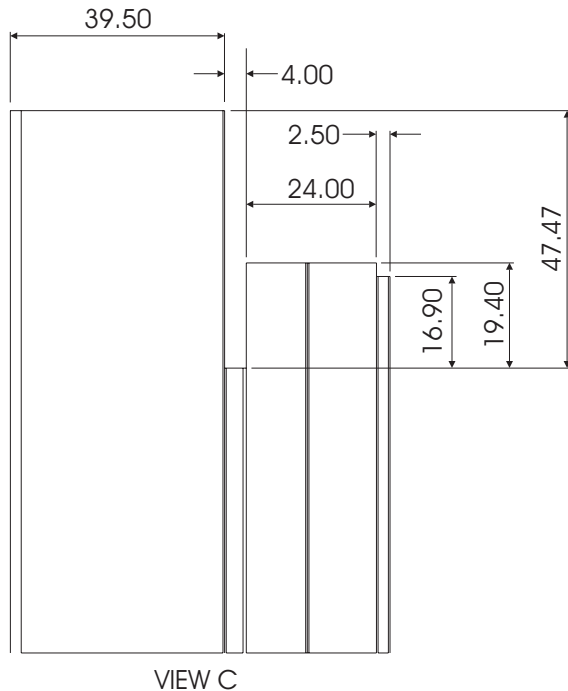
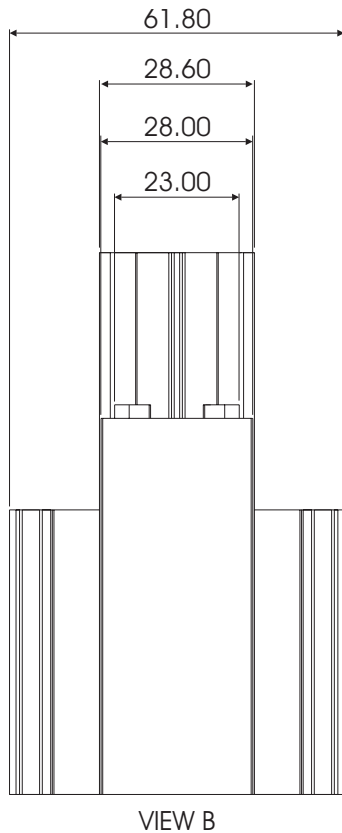
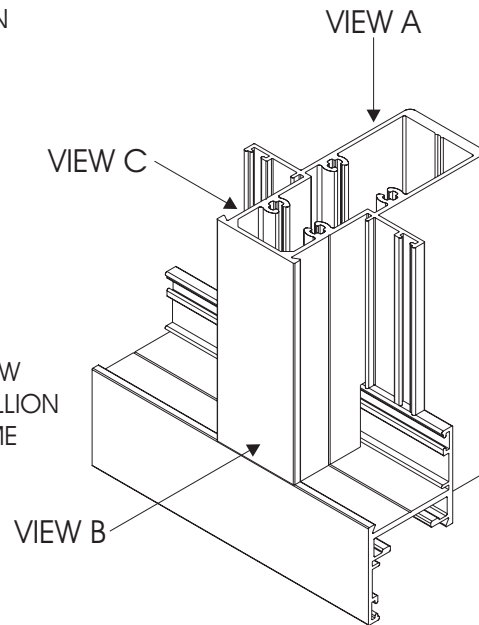
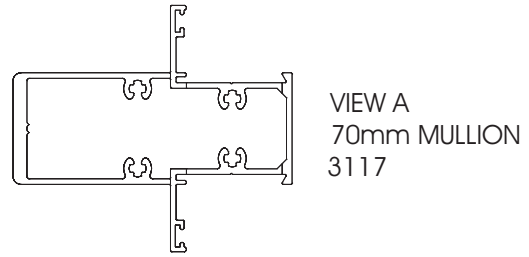
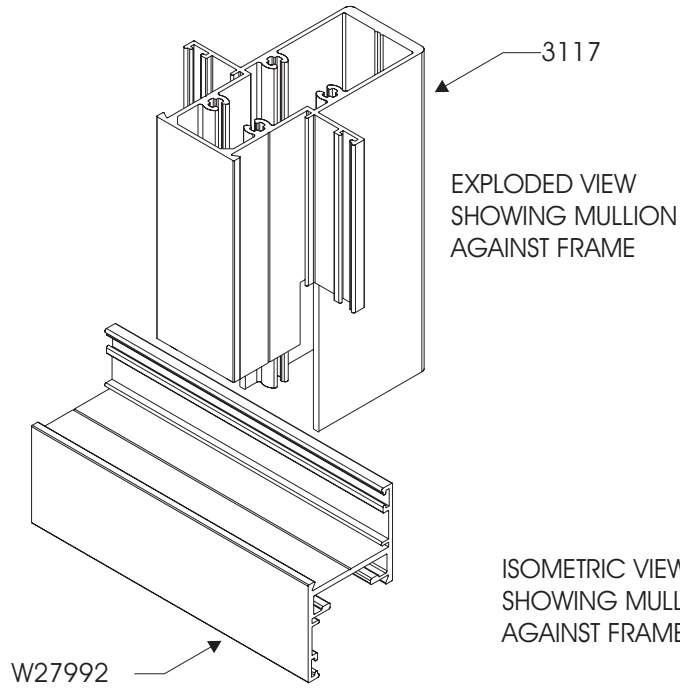

Disclaimer: The right to make alterations is reserved
 © 2010 Sheerline, All Rights Reserved

SHEERSASH 30.5 WINDOW SYSTEM
70mm MULLION MACHINING



DETAIL FOR END MILLING ON 54mm OUTER FRAME

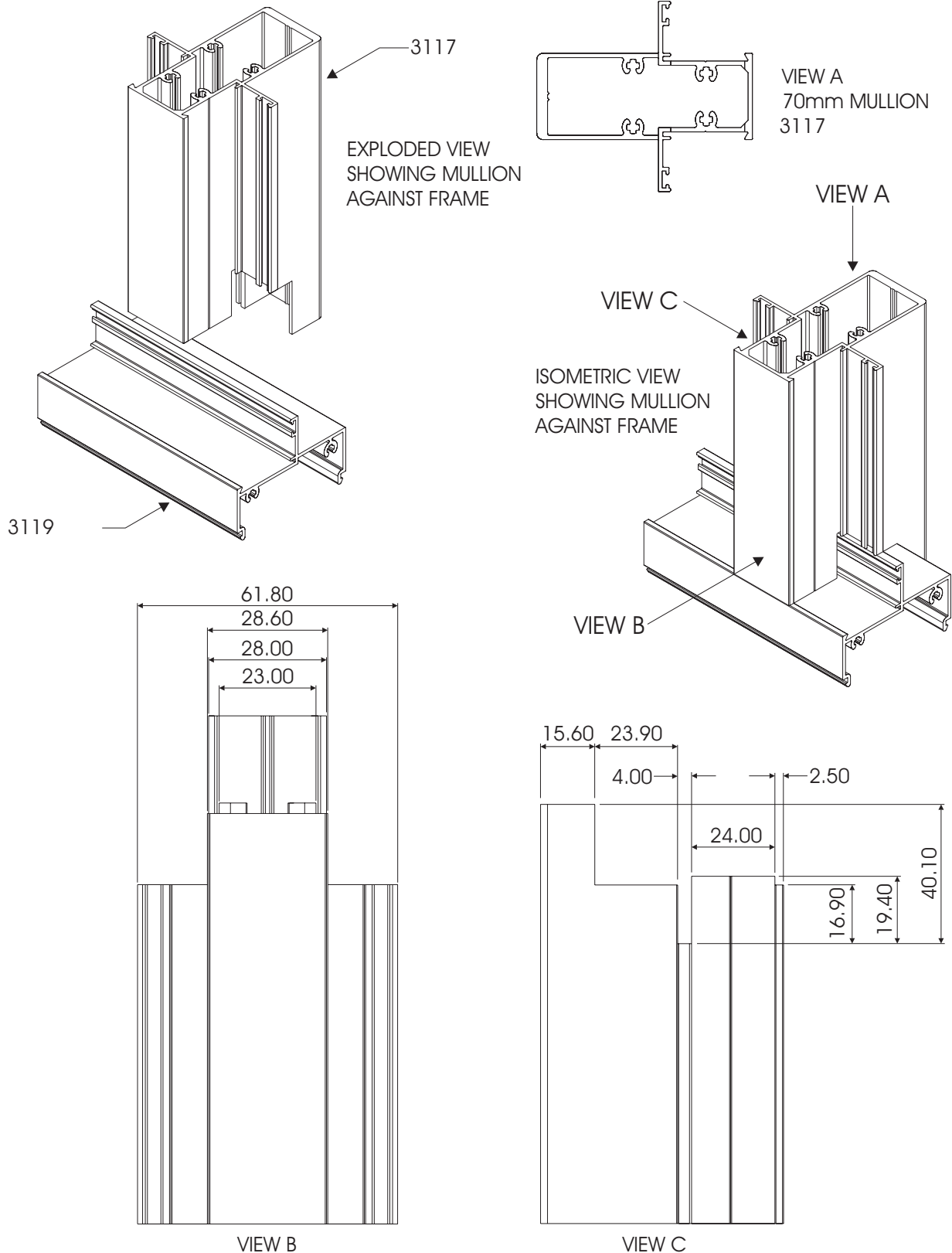

Disclaimer: The right to make alterations is reserved
© 2010 Sheerline, All Rights Reserved

SHEERSASH 30.5 WINDOW SYSTEM
 70mm MULLION MACHINING
 DETAIL FOR END MILLING
 ON 70mm OUTER FRAME

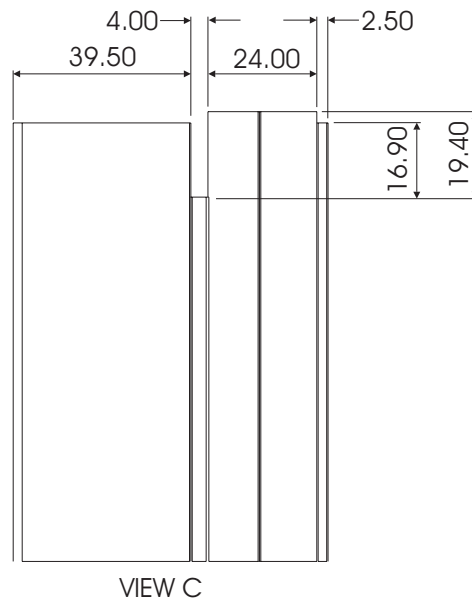
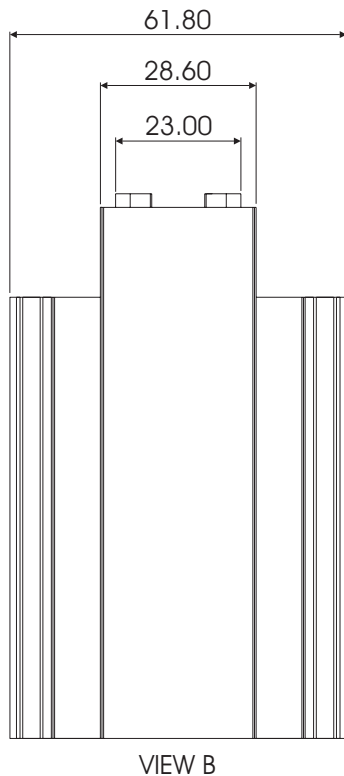
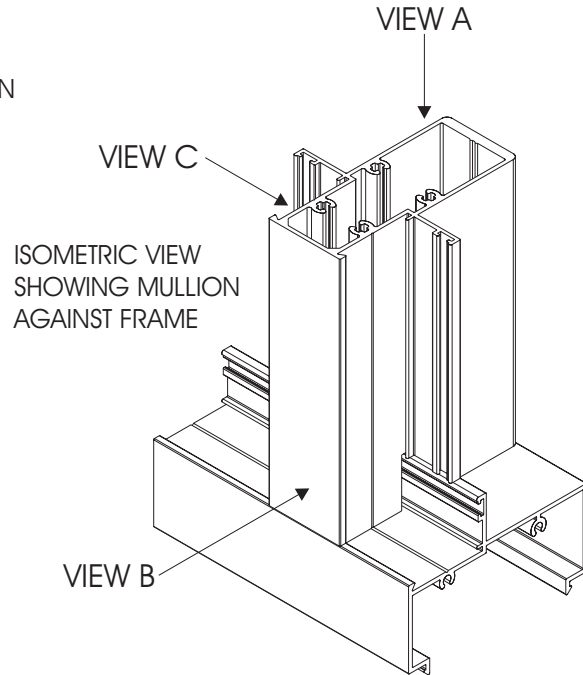
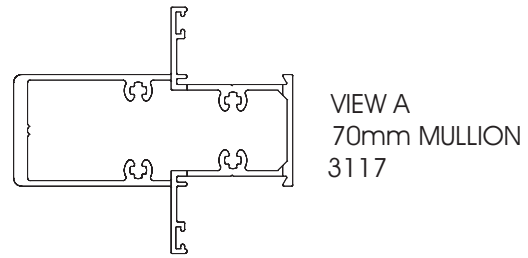
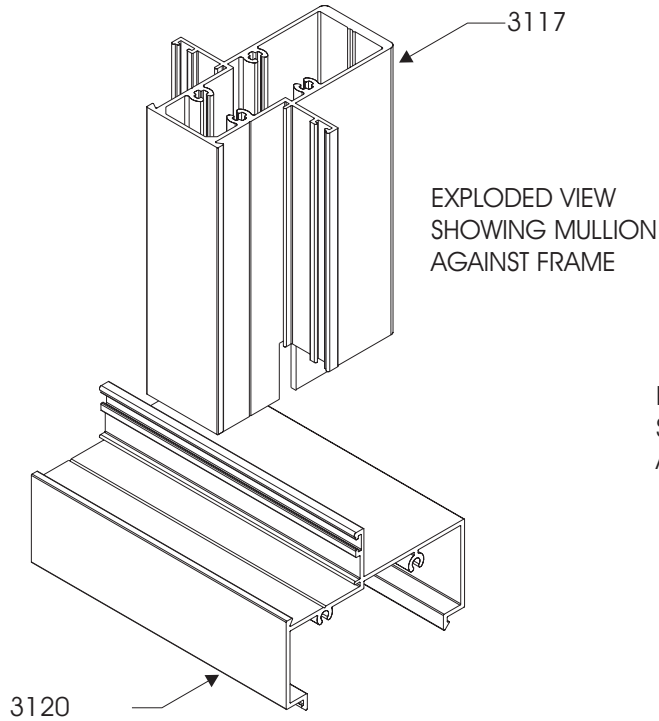

Disclaimer: The right to make alterations is reserved
 © 2010 Sheerline, All Rights Reserved

SHEERSASH 30.5 WINDOW SYSTEM
 70mm MULLION MACHINING
 DETAIL FOR END MILLING
 ON LITE EQUAL LEG OUTER FRAME

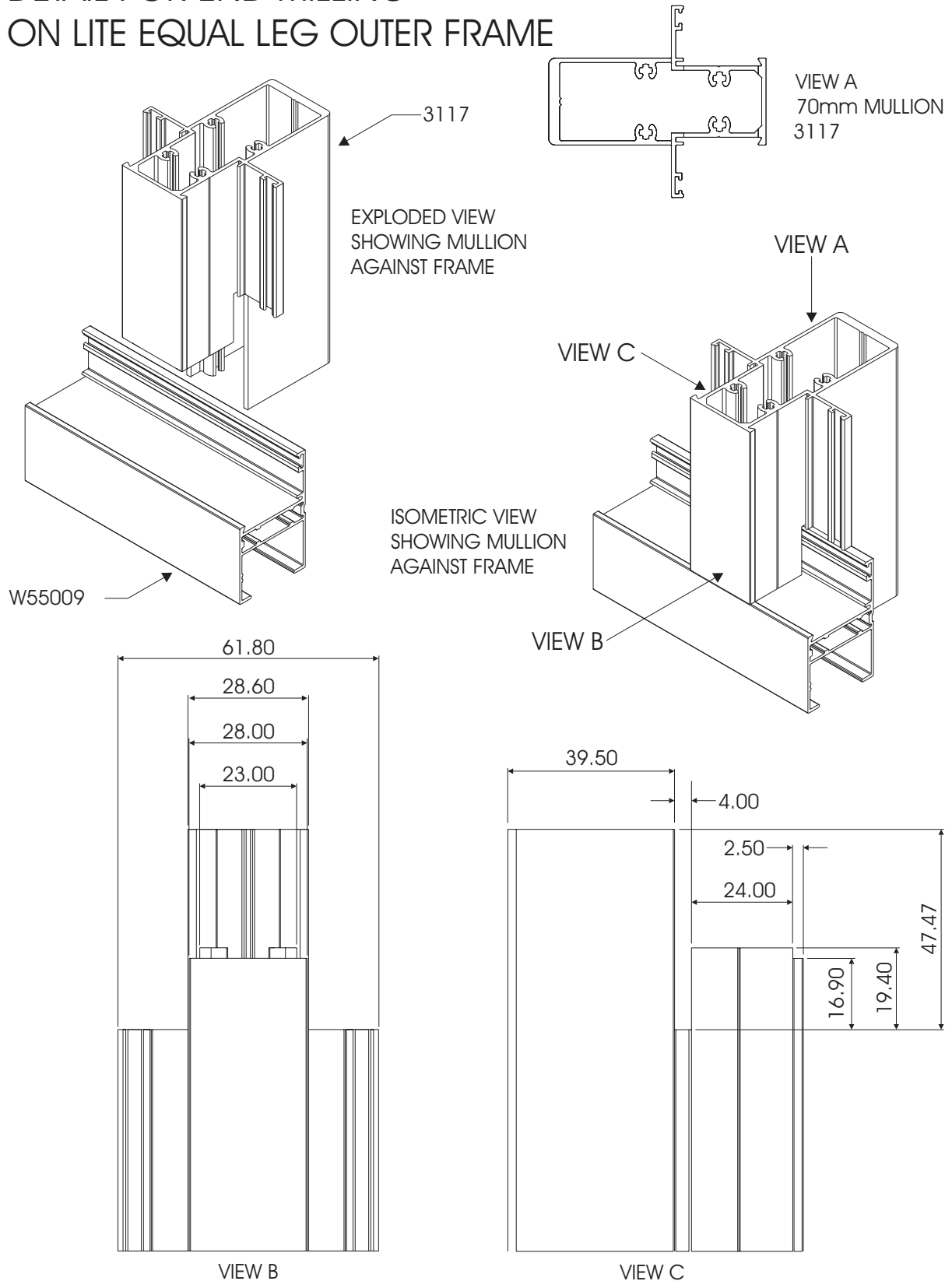

Disclaimer: The right to make alterations is reserved
 © 2010 Sheerline, All Rights Reserved

SHEERSASH 30.5 WINDOW SYSTEM
 COTTAGE PANE MULLION
 MACHINING DETAIL FOR END MILLING
 ON EQUAL LEG OUTER FRAME

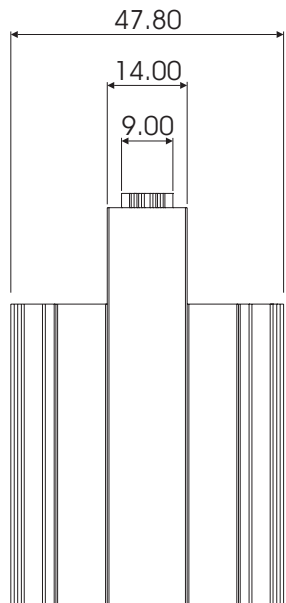
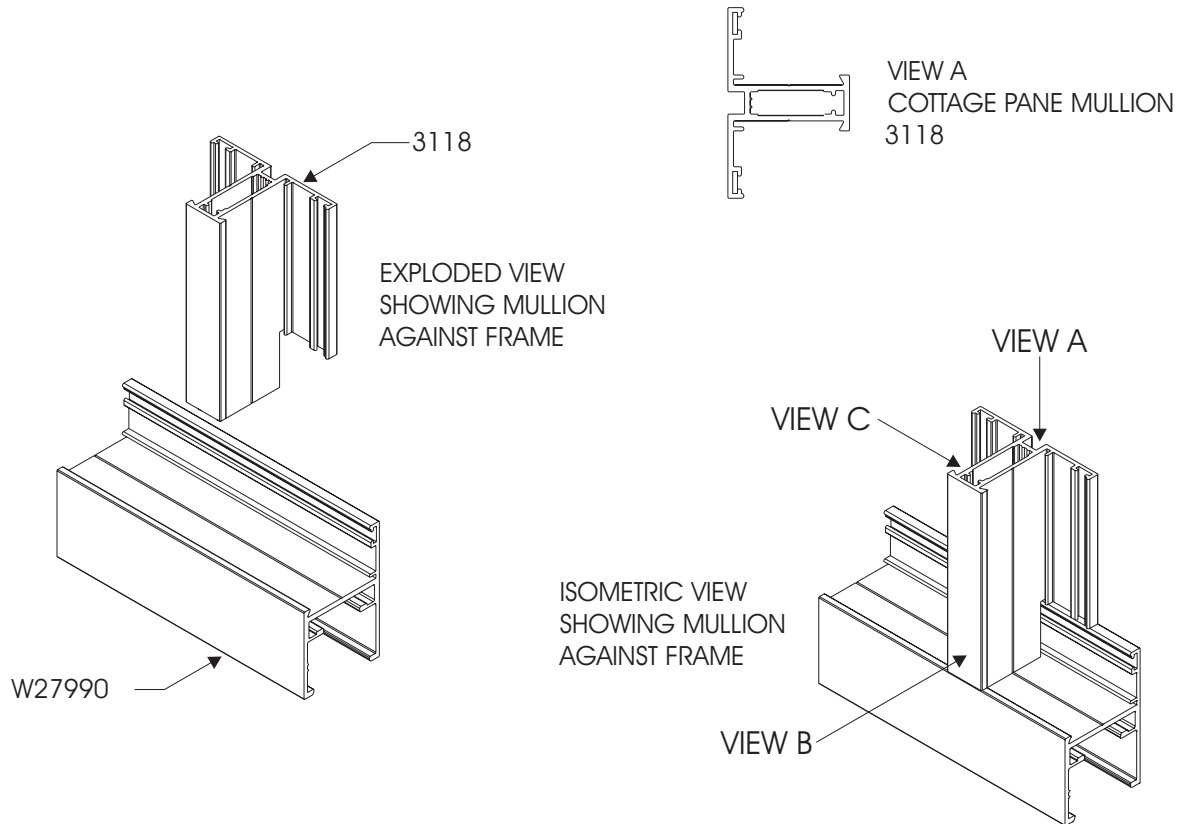

VIEW B

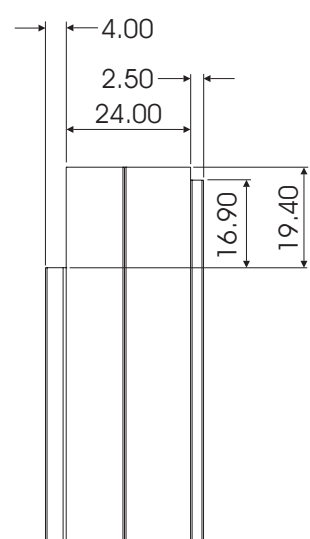

VIEW C

Disclaimer: The right to make alterations is reserved
 © 2010 Sheerline, All Rights Reserved

SHEERSASH 30.5 WINDOW SYSTEM
 COTTAGE PANE MULLION
 MACHINING DETAIL FOR END MILLING
 ON UNEQUAL LEG OUTER FRAME

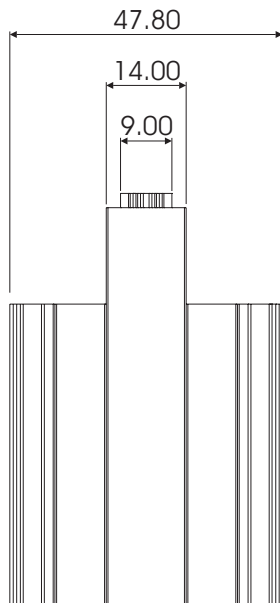
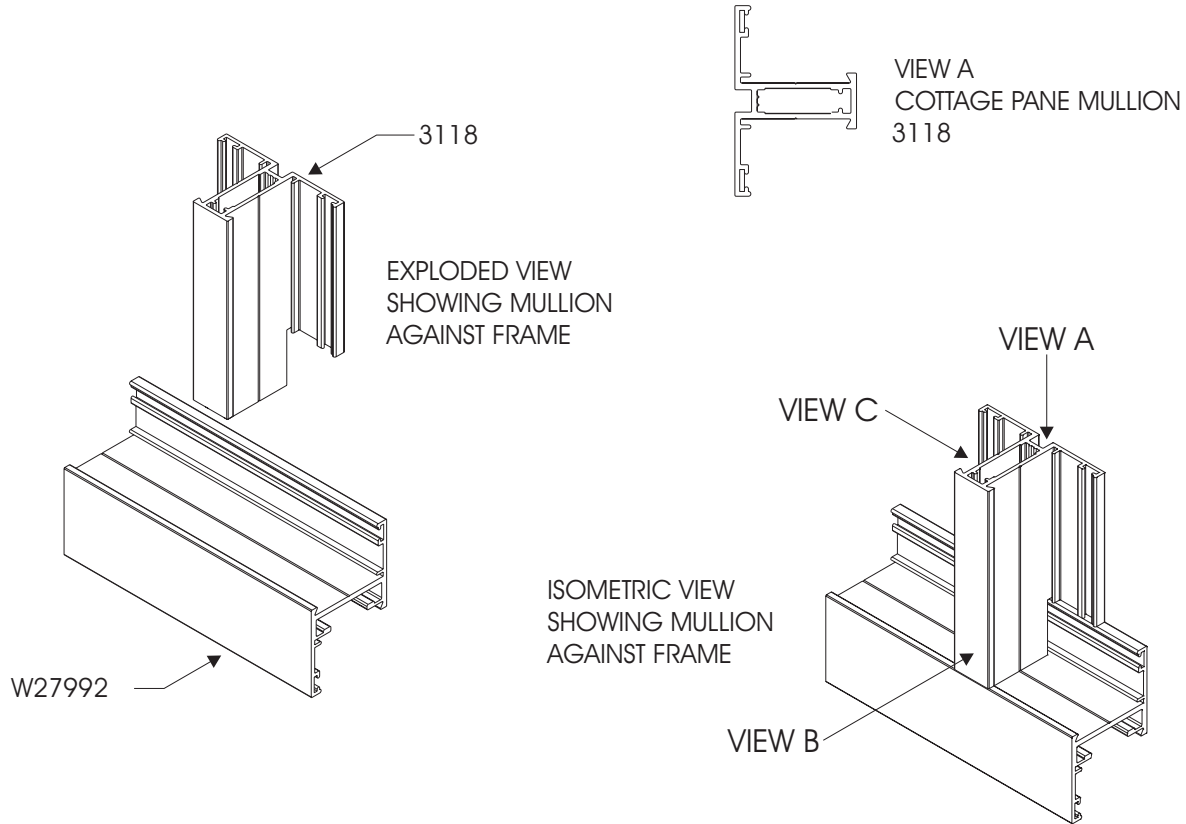

VIEW B

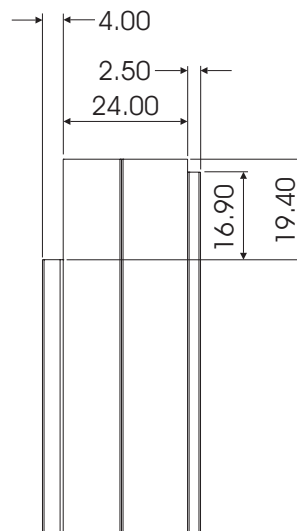

VIEW C

Disclaimer: The right to make alterations is reserved
 © 2010 Sheerline, All Rights Reserved

SHEERSASH 30.5 WINDOW SYSTEM
 COTTAGE PANE MULLION
 MACHINING DETAIL FOR END MILLING
 ON 54mm OUTER FRAME

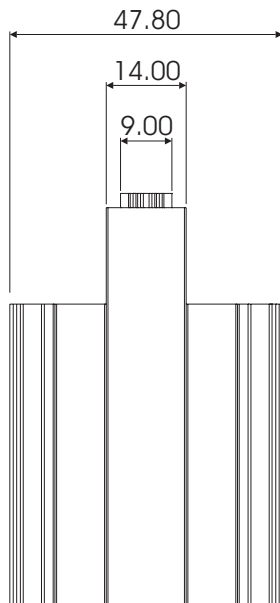
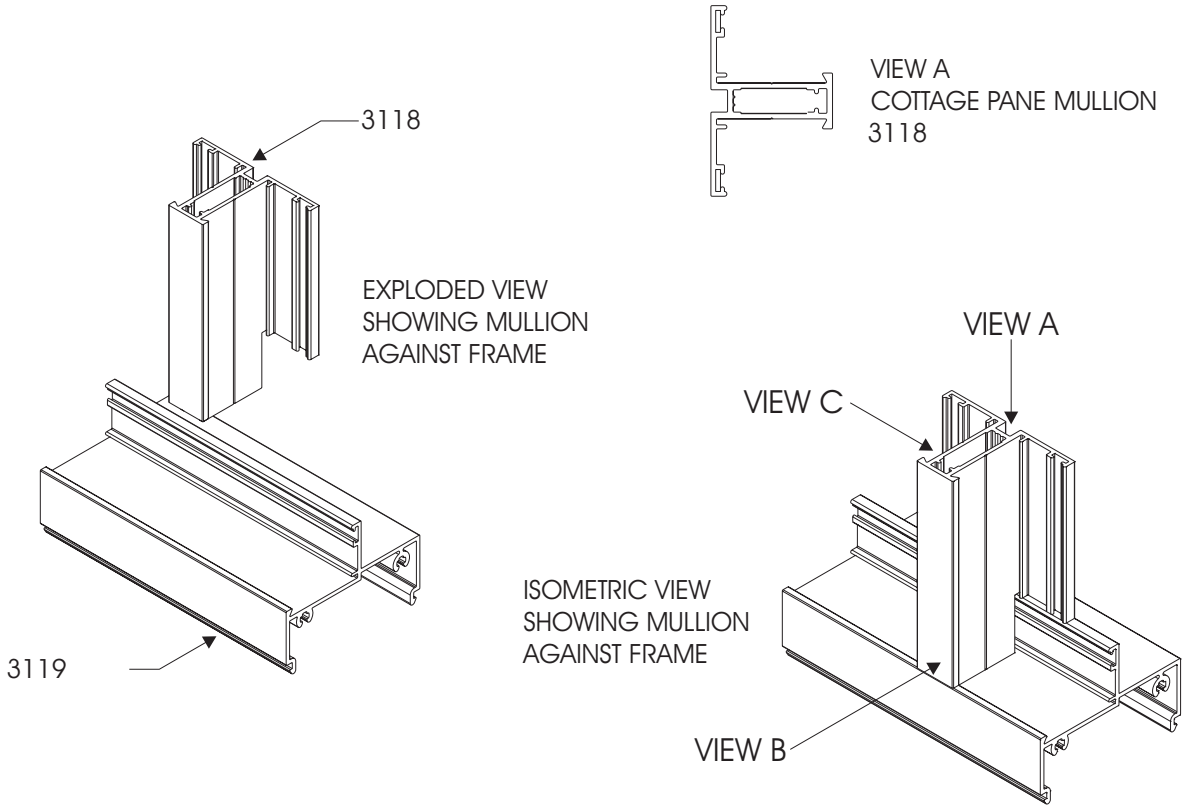

VIEW B

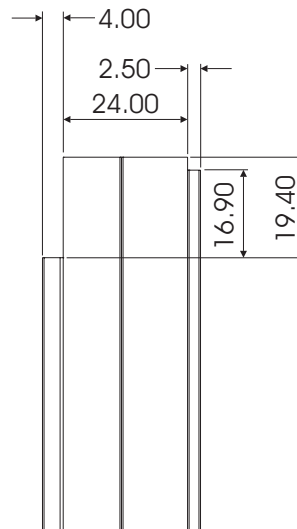

VIEW C

SHEERSASH 30.5 WINDOW SYSTEM
 COTTAGE PANE MULLION
 MACHINING DETAIL FOR END MILLING
 ON 70mm OUTER FRAME

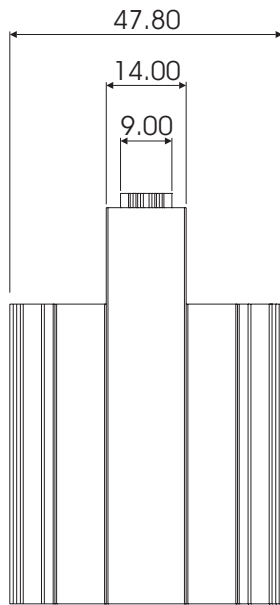
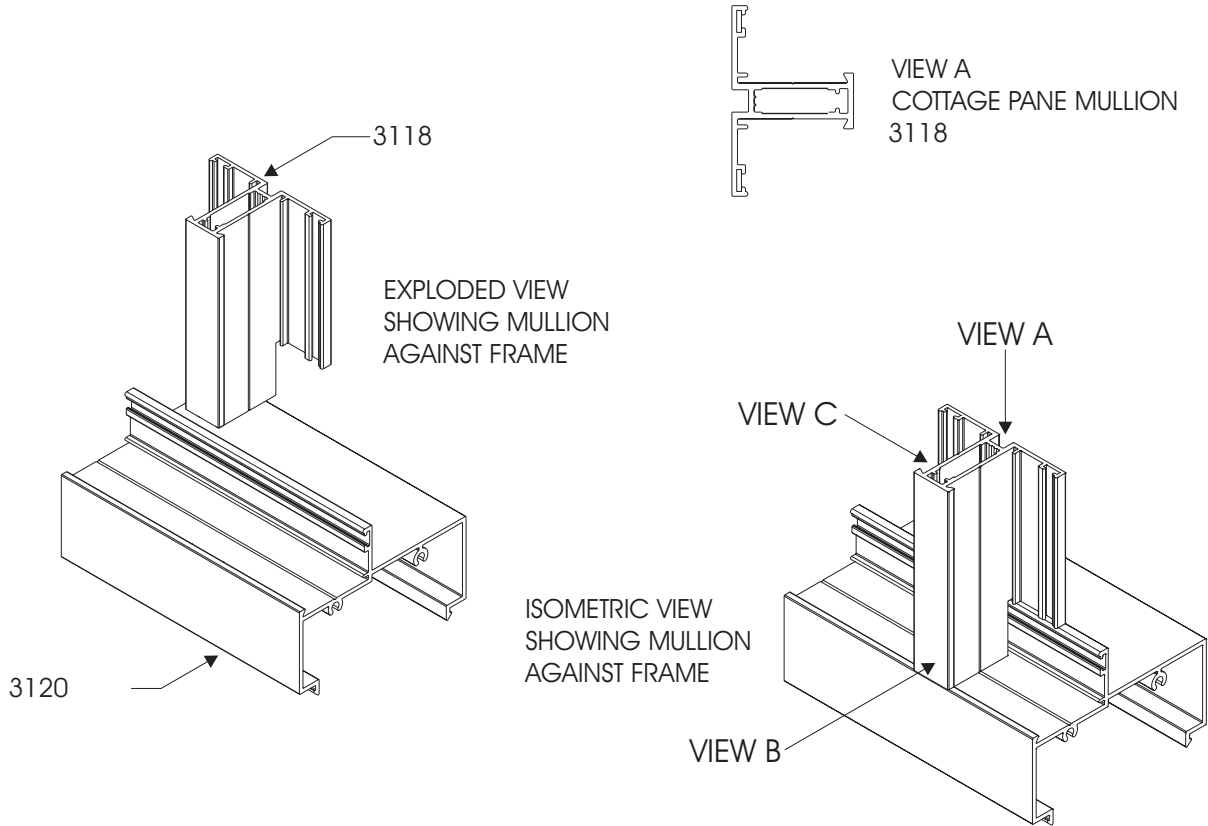

VIEW B

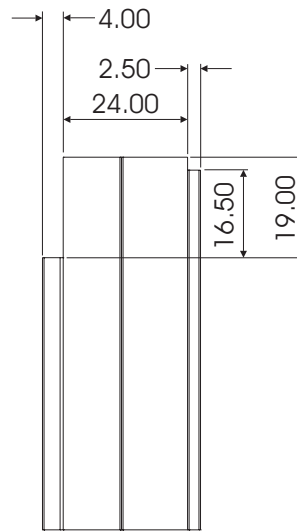

VIEW C

Disclaimer: The right to make alterations is reserved
 © 2010 Sheerline, All Rights Reserved

SHEERSASH 30.5 WINDOW SYSTEM
 LITE MULLION MACHINING
 DETAIL FOR END MILLING
 ON EQUAL LEG OUTER FRAME

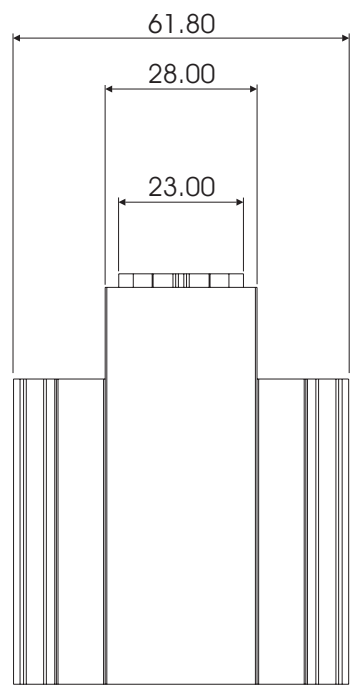
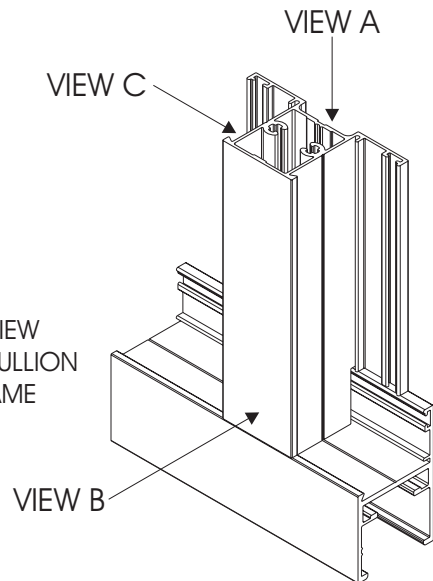
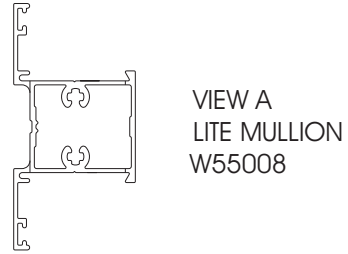
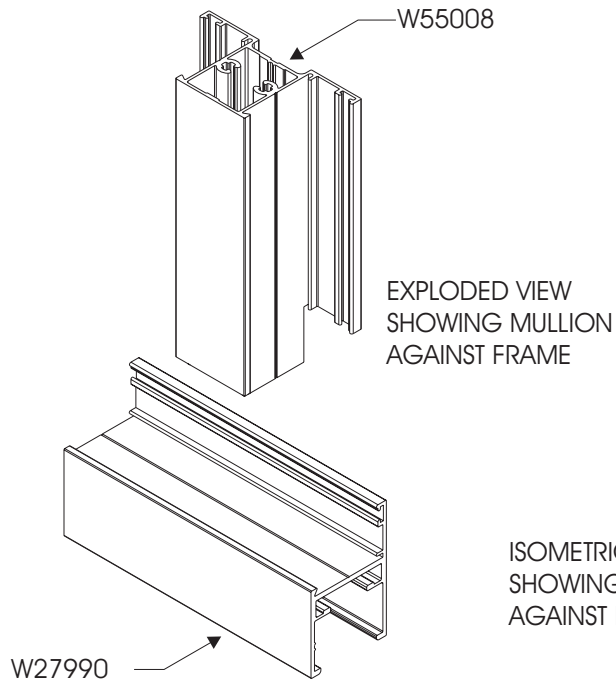

VIEW B

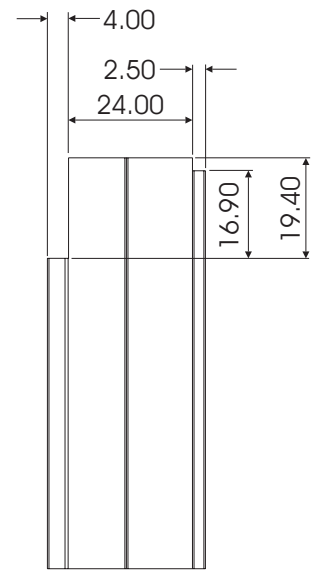

VIEW C

Disclaimer: The right to make alterations is reserved
 © 2010 Sheerline, All Rights Reserved

SHEERSASH 30.5 WINDOW SYSTEM
 LITE MULLION MACHINING
 DETAIL FOR END MILLING
 ON UNEQUAL LEG OUTER FRAME

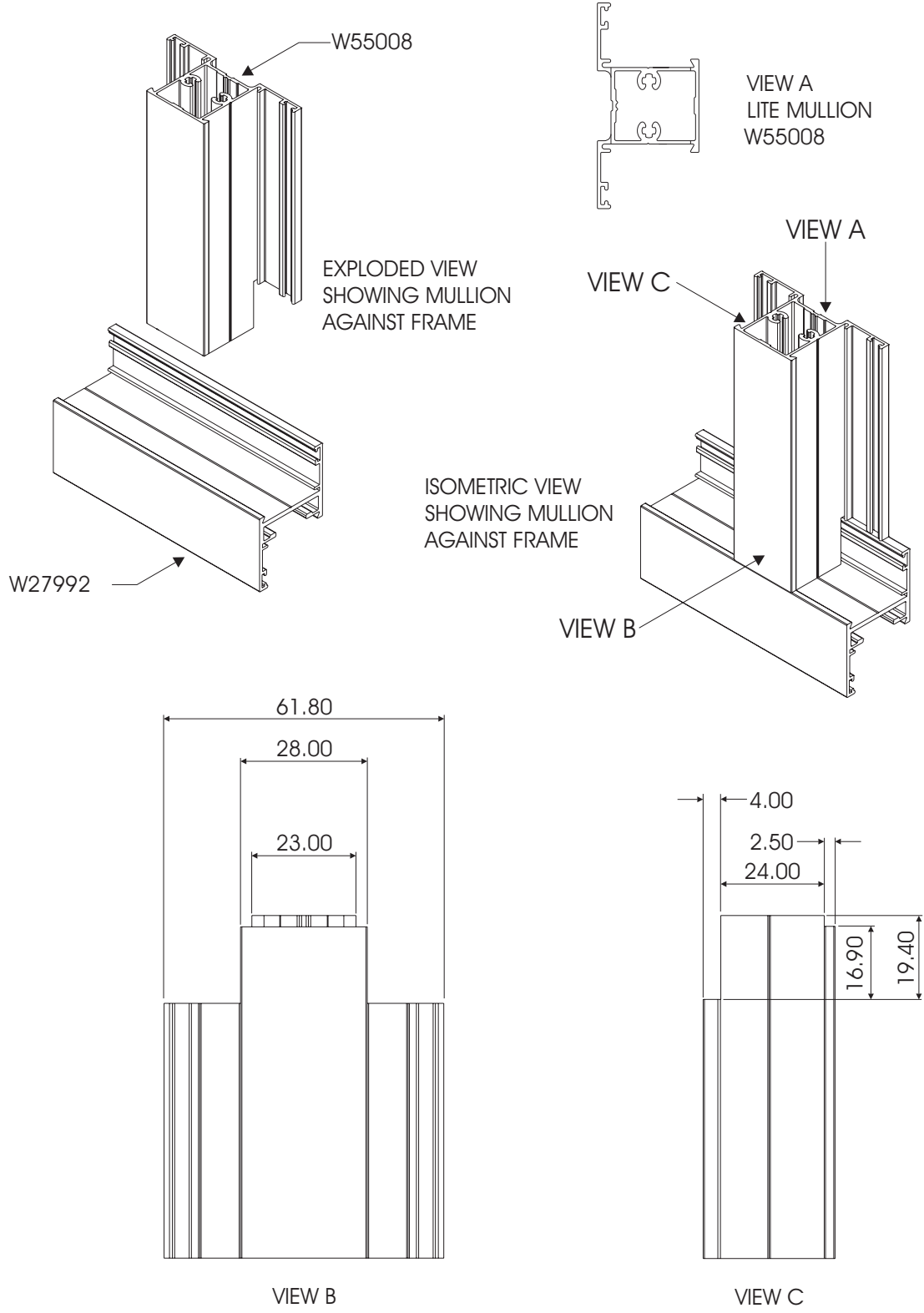

Disclaimer: The right to make alterations is reserved
 © 2010 Sheerline, All Rights Reserved

SHEERSASH 30.5 WINDOW SYSTEM
 LITE MULLION MACHINING
 DETAIL FOR END MILLING
 ON 54mm OUTER FRAME

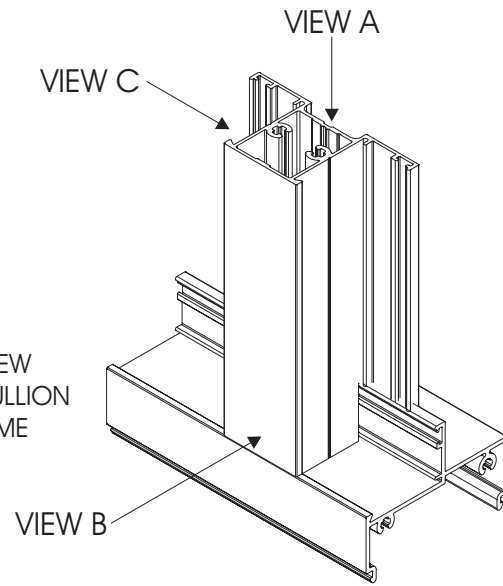
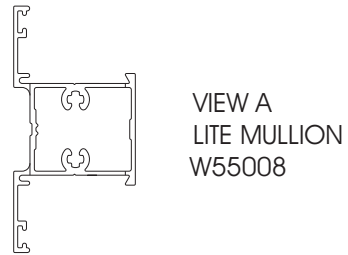
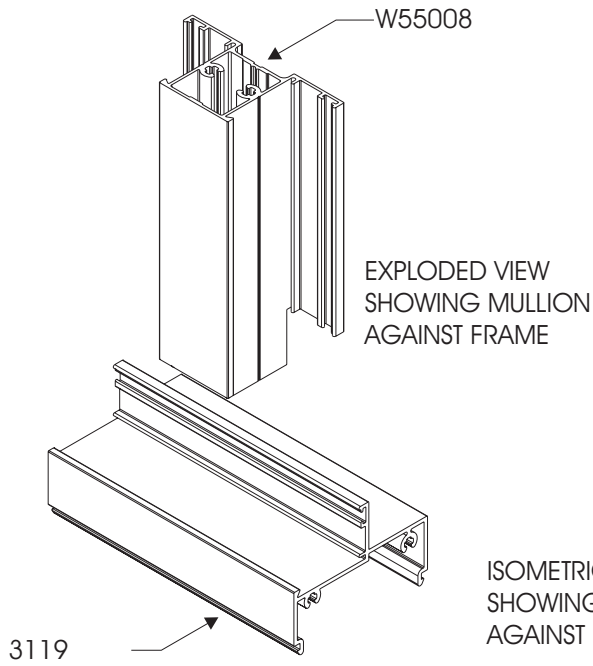

ISOMETRIC VIEW
 SHOWING MULLION
 AGAINST FRAME

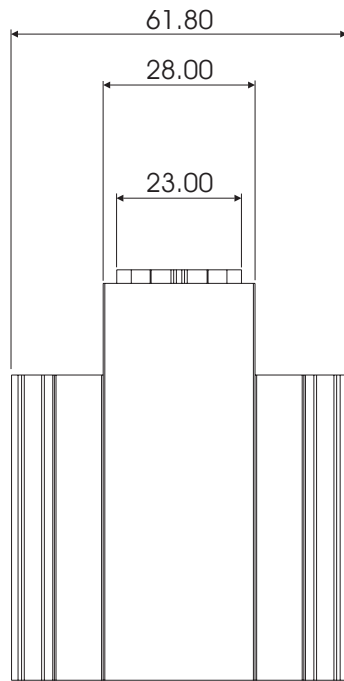

VIEW B

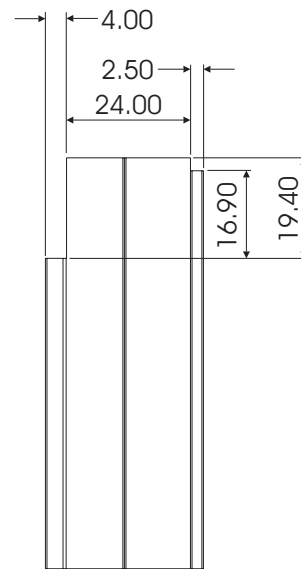

VIEW C

SHEERSASH 30.5 WINDOW SYSTEM
 LITE MULLION MACHINING
 DETAIL FOR END MILLING
 ON 70mm OUTER FRAME

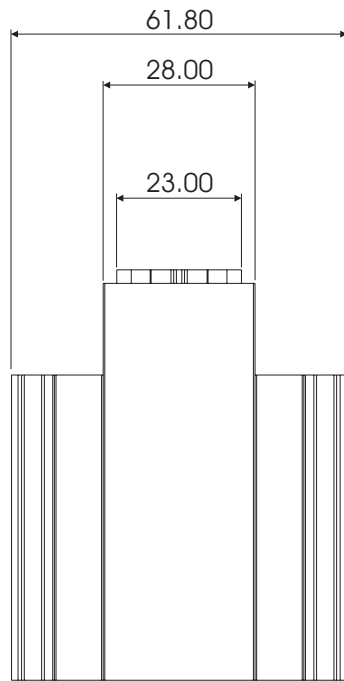
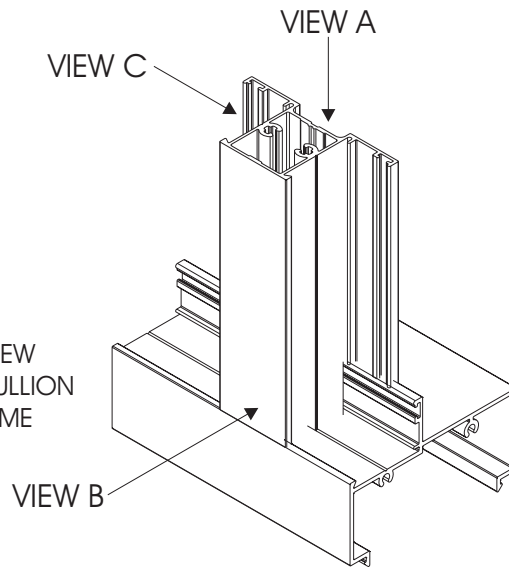
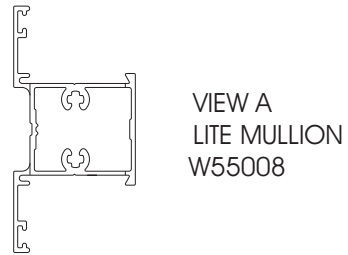
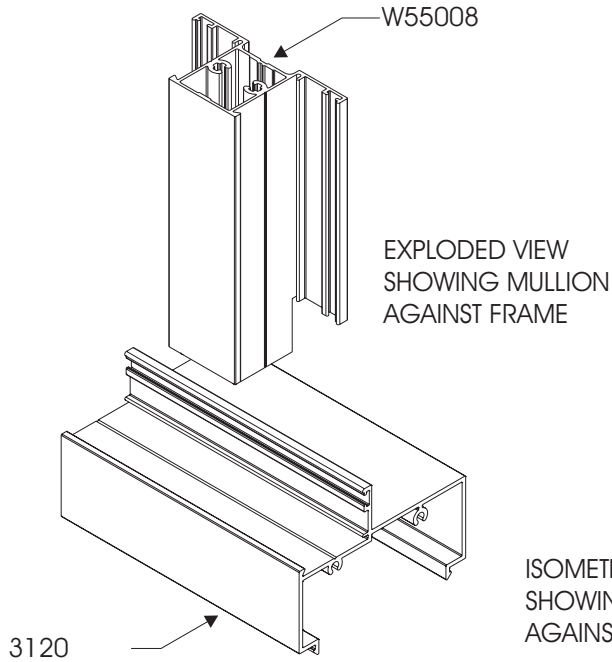

VIEW B

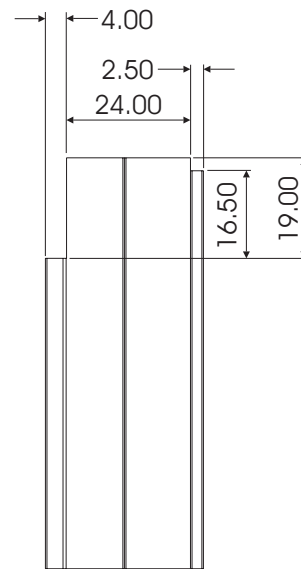

VIEW C

Disclaimer: The right to make alterations is reserved
 © 2010 Sheerline, All Rights Reserved

SHEERSASH 30.5 WINDOW SYSTEM
 LITE MULLION MACHINING
 DETAIL FOR END MILLING
 ON LITE EQUAL LEG OUTER FRAME

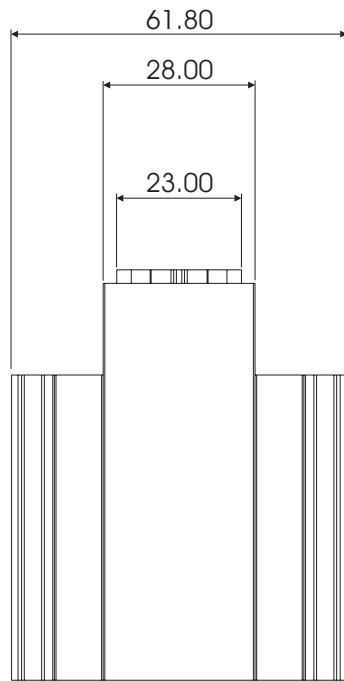
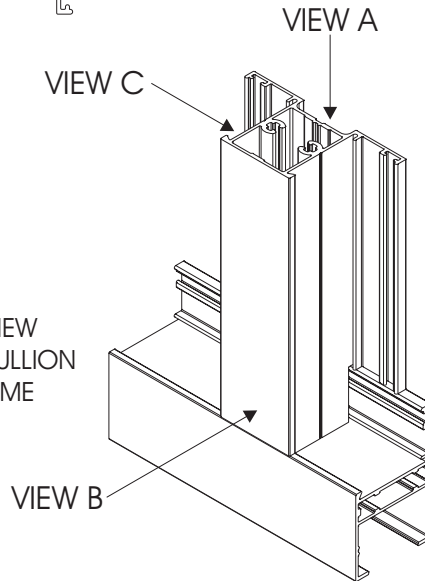
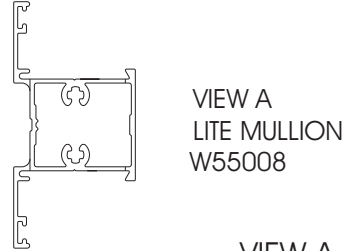
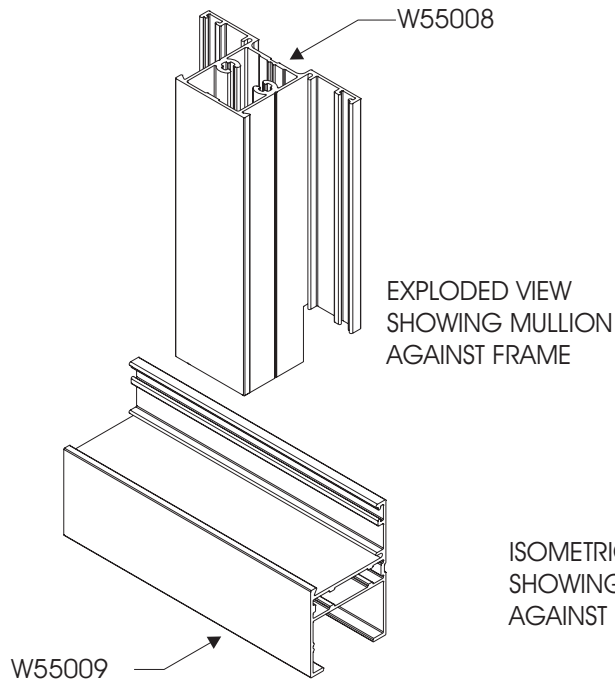

VIEW B

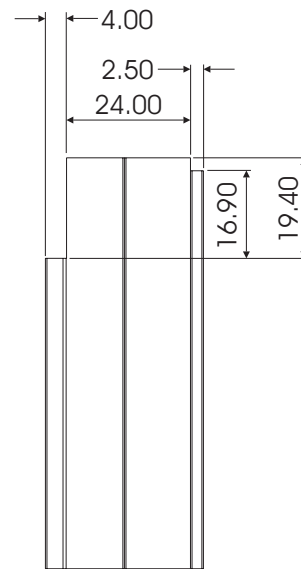

VIEW C

Disclaimer: The right to make alterations is reserved
 © 2010 Sheerline, All Rights Reserved

SHEERSASH 30.5 WINDOW SYSTEM CORNER CLEAT ASSEMBLY DETAIL FOR LITE TUBULAR SASH

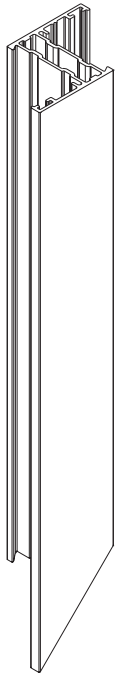

NOTE:
ALL JOINTS MUST BE SEALED WITH
SMALL JOINT SEALANT. FINPILE
MUST BE FITTED TO SASH AND
CORRESPONDING SURFACES OF
FRAME BEFORE CRIMPING (NOT
TO AREAS TO BE GLAZED)

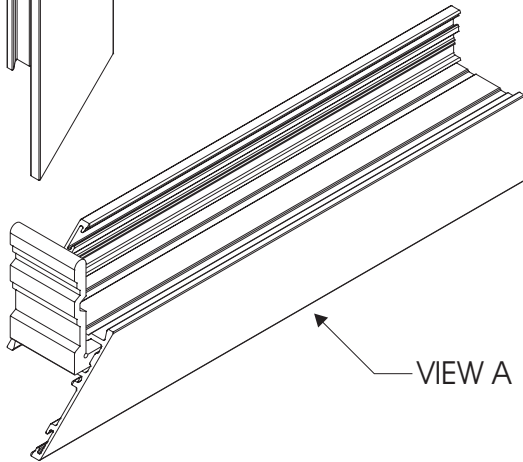
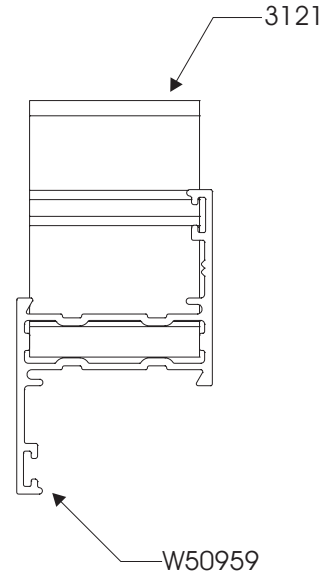

THE CORNER CLEAT HAS BEEN
SPECIALLY DESIGNED SO THAT THE
CORNER CAN BE CRIMPED EITHER
FROM THE INSIDE WITH A HAND
OPERATED CRIMPING MACHINE
OR FROM THE OUTSIDE WITH A
HYDRAULICALLY OPERATED
CRIMPING MACHINE

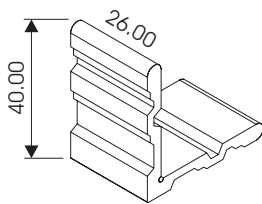

3121

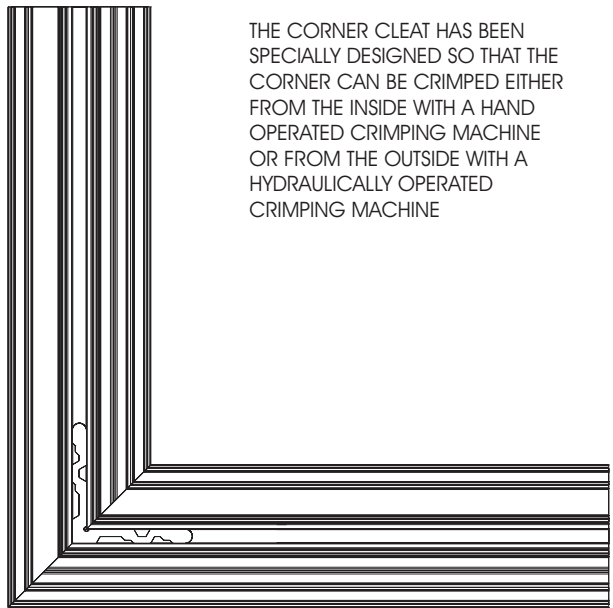

VIEW A

SHEERSASH 30.5 WINDOW SYSTEM GLAZING BAR FRAME JOINT ASSEMBLY DETAIL



NOTE: ALL JOINTS MUST BE SEALED WITH SMALL JOINT SEALANT. FINPILE MUST BE FITTED PRIOR TO ASSEMBLY IF SASH IS TO BE FITTED INTO FRAME. FINPLIE MUST NOT RUN BEHIND GLAZING BAR AND GAP MUST BE SEALED TO PREVENT WATER INFILTRATION.

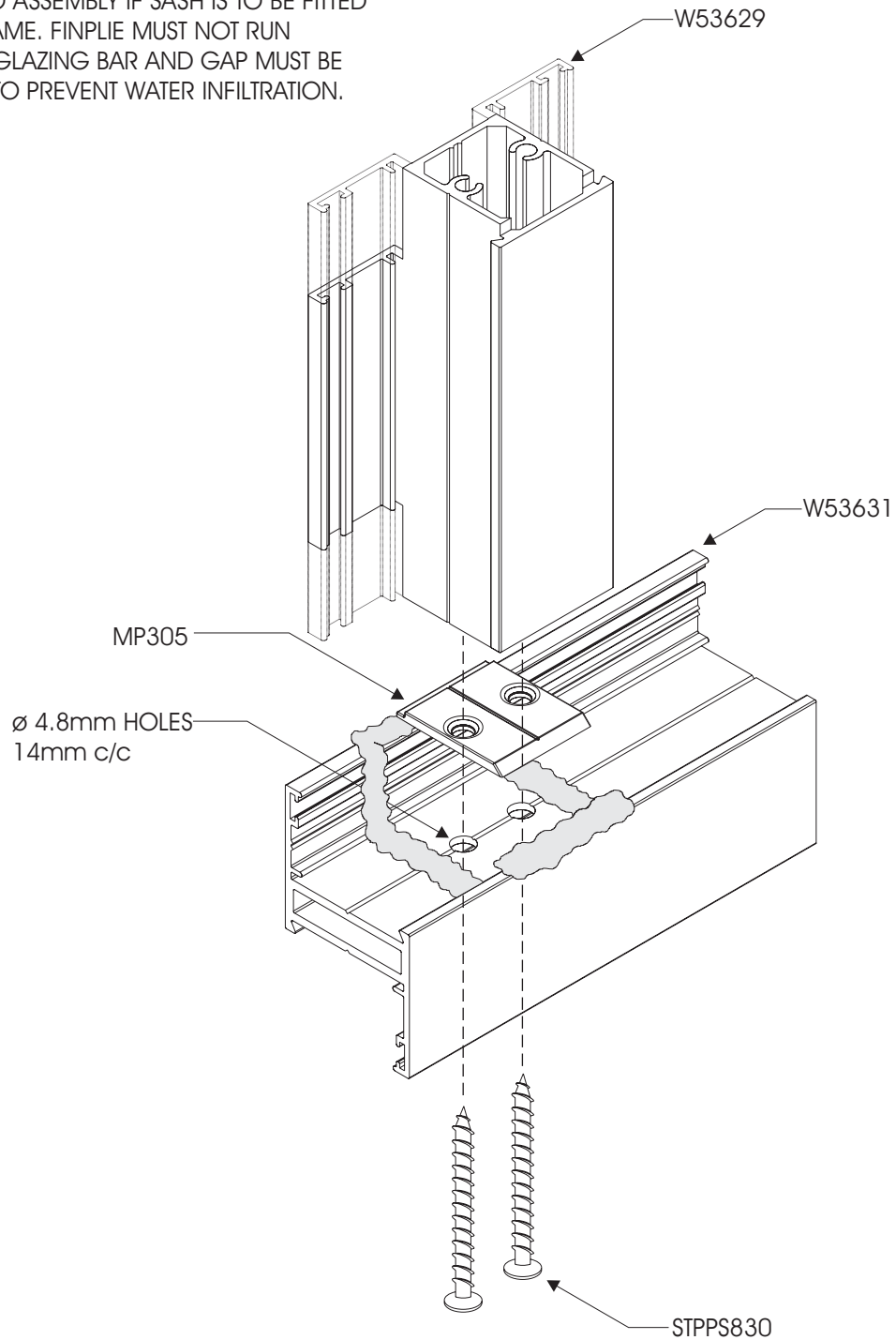

SHEERSASH 30.5 LITE WINDOW GLAZING BAR FRAME JOINT ASSEMBLY DETAIL



NOTE: ALL JOINTS MUST BE SEALED WITH SMALL JOINT SEALANT. FINPILE MUST BE FITTED PRIOR TO ASSEMBLY IF SASH IS TO BE FITTED INTO FRAME. FINPLIE MUST NOT RUN BEHIND GLAZING BAR AND GAP MUST BE SEALED TO PREVENT WATER INFILTRATION.

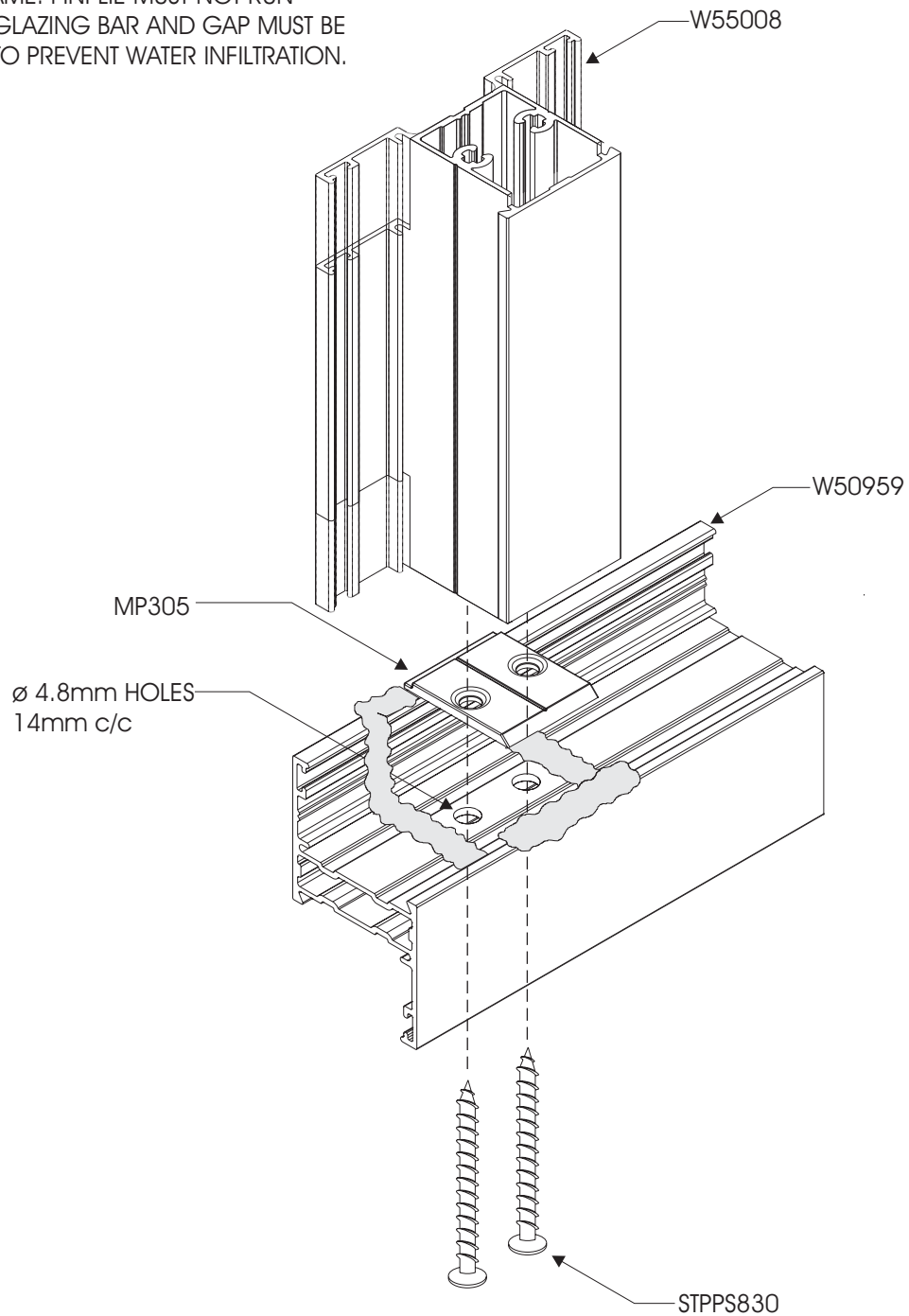

Disclaimer: The right to make alterations is reserved
© 2010 Sheerline, All Rights Reserved

SHEERSASH 30.5 WINDOW SYSTEM CROSS JOINT ASSEMBLY DETAIL STANDARD MULLION



NOTE: ALL JOINTS MUST BE SEALED WITH SMALL JOINT SEALANT. FINPILE MUST BE FITTED PRIOR TO ASSEMBLY IF SASH IS TO BE FITTED INTO FRAME. FINPILE MUST NOT RUN BEHIND GLAZING BAR AND GAP MUST BE SEALED TO PREVENT WATER INFILTRATION.

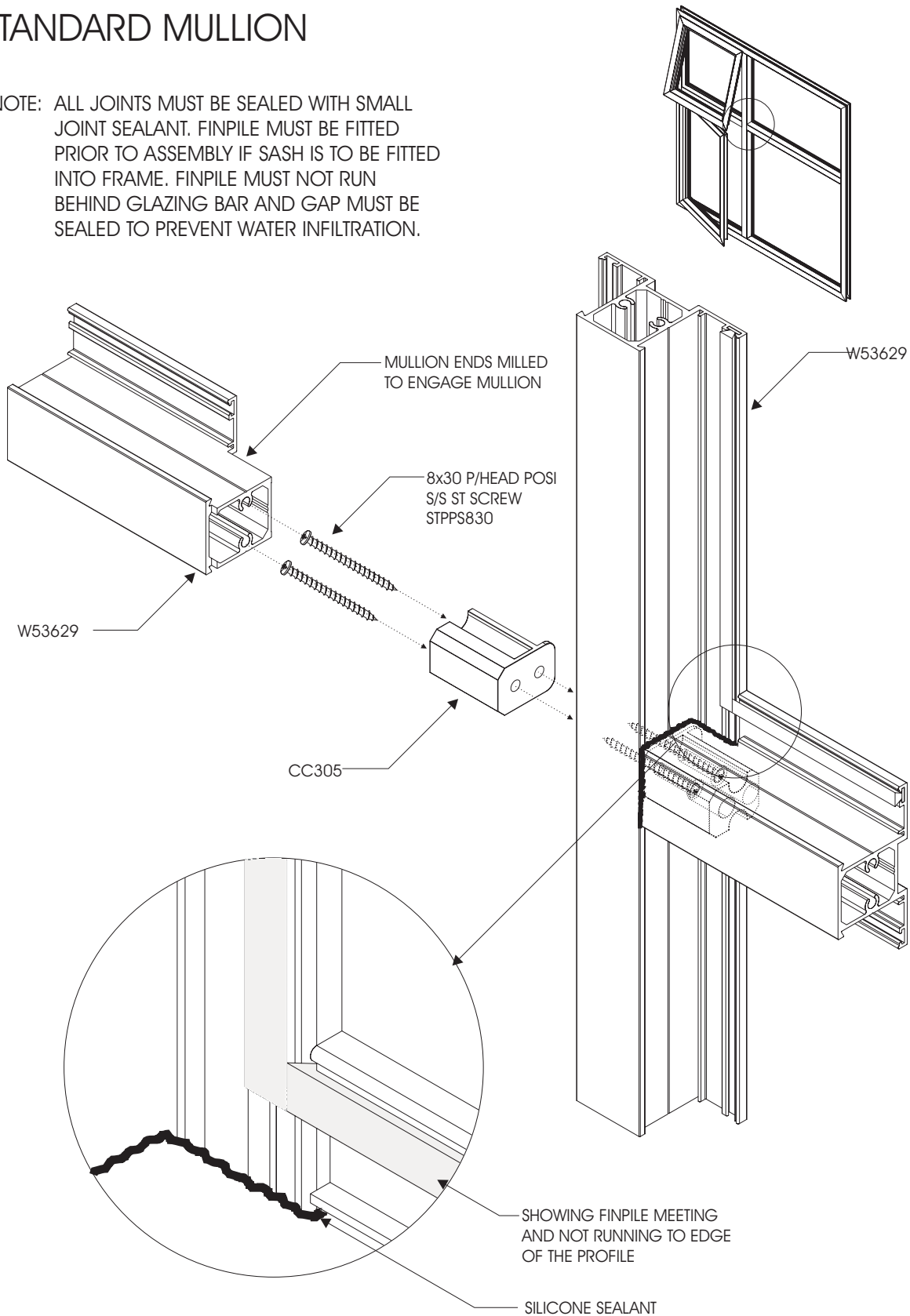

Disclaimer: The right to make alterations is reserved
© 2010 Sheerline, All Rights Reserved

SHEERSASH 30.5 WINDOW SYSTEM CROSS JOINT ASSEMBLY DETAIL LITE MULLION



NOTE: ALL JOINTS MUST BE SEALED WITH SMALL JOINT SEALANT. FINPILE MUST BE FITTED PRIOR TO ASSEMBLY IF SASH IS TO BE FITTED INTO FRAME. FINPILE MUST NOT RUN BEHIND GLAZING BAR AND GAP MUST BE SEALED TO PREVENT WATER INFILTRATION.

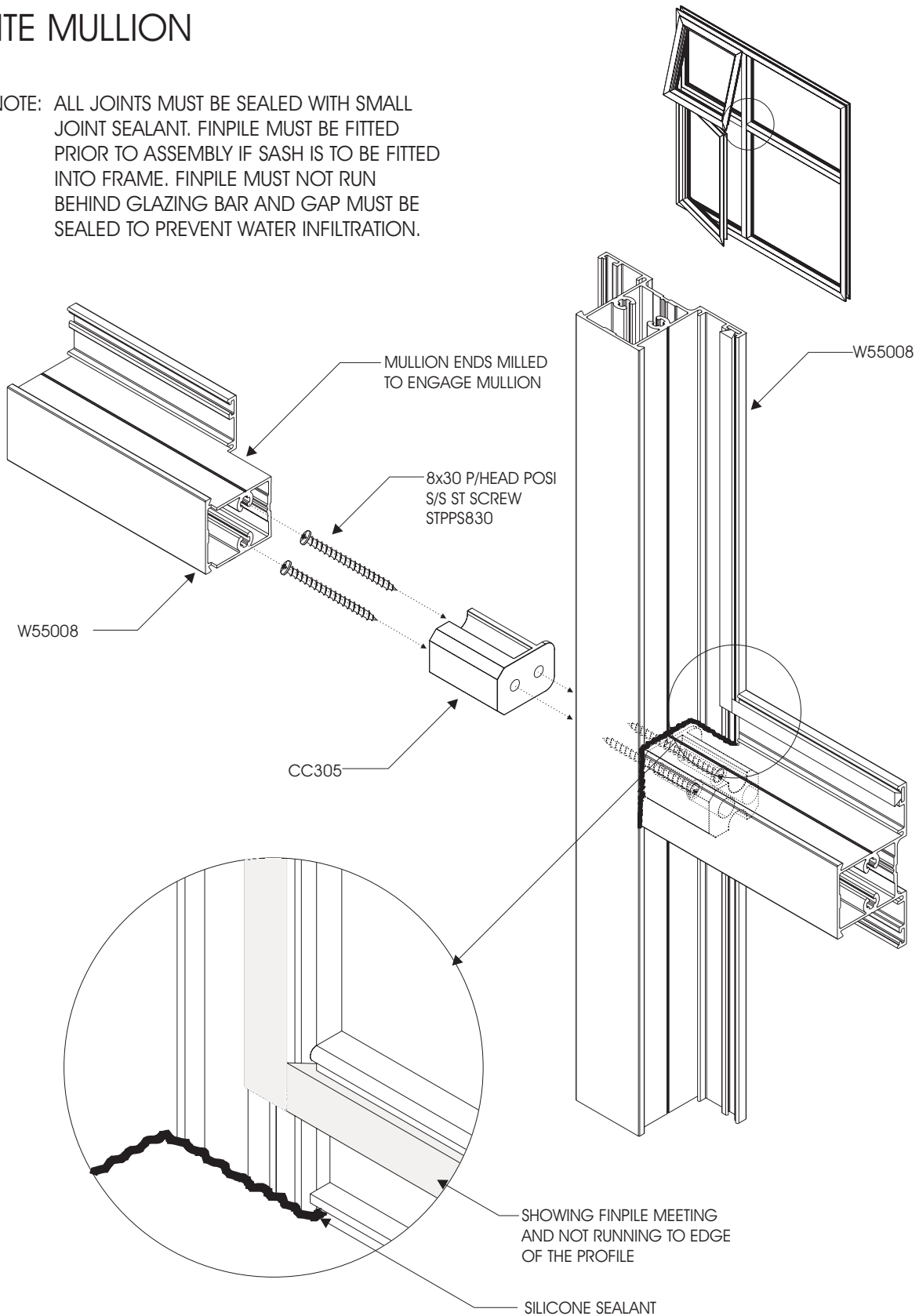

Disclaimer: The right to make alterations is reserved
© 2010 Sheerline, All Rights Reserved

SHEERSASH 30.5 WINDOW SYSTEM CROSS JOINT ASSEMBLY DETAIL COTTAGE PANE MULLION

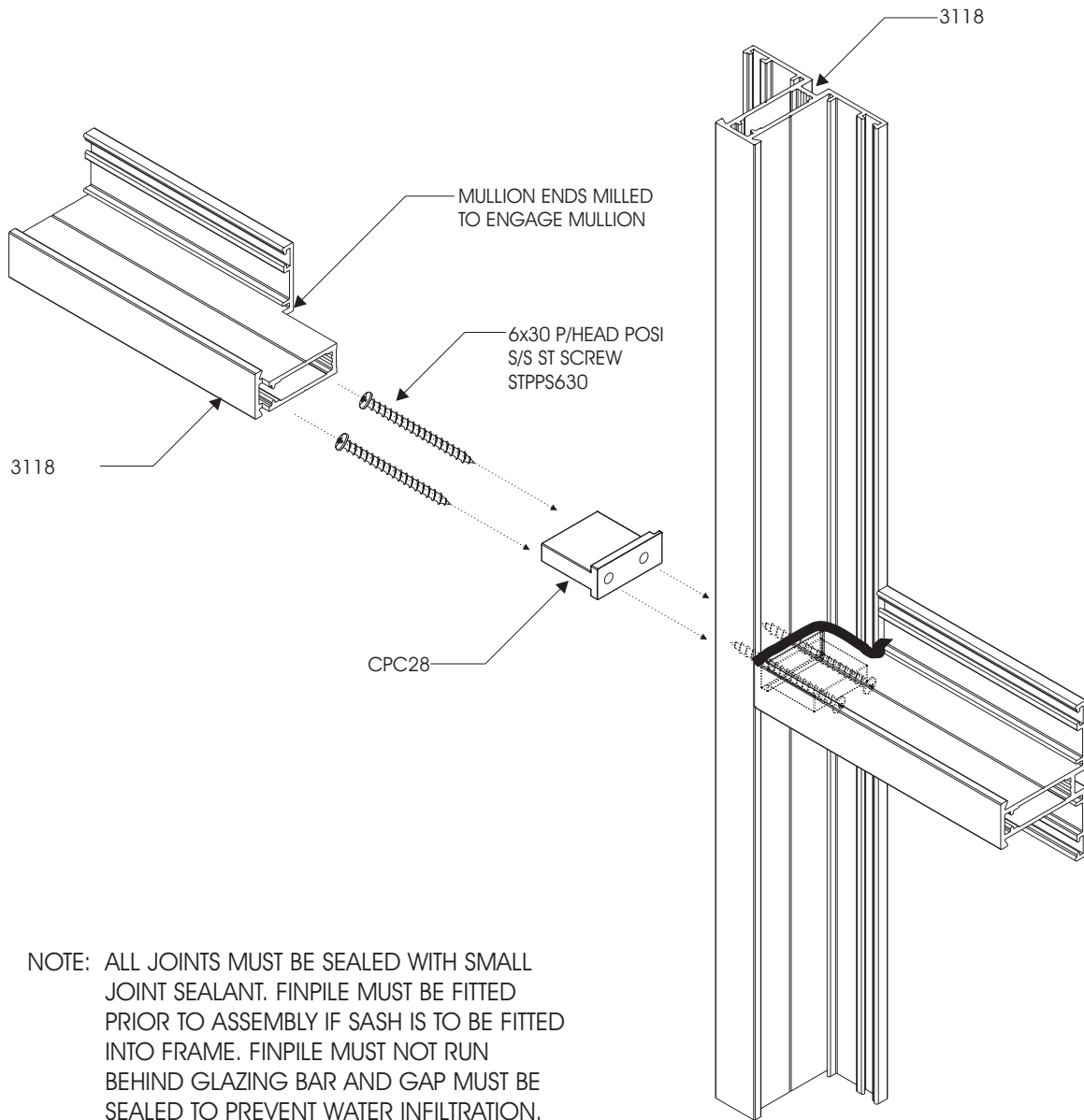

NOTE: ALL JOINTS MUST BE SEALED WITH SMALL JOINT SEALANT. FINPILE MUST BE FITTED PRIOR TO ASSEMBLY IF SASH IS TO BE FITTED INTO FRAME. FINPILE MUST NOT RUN BEHIND GLAZING BAR AND GAP MUST BE SEALED TO PREVENT WATER INFILTRATION.

SHEERSASH 30.5 WINDOW SYSTEM GLAZING PROCEDURE



Insert the pull-in vinyl gasket into glazing beads by sliding or pressing it into the groove (1). Before cutting gasket, ensure that it has not stretched and cut 6mm longer so that corners are in compression at all times.

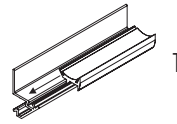

Position bottom glazing bead in glazing bead rebate (2).

Place glass on glazing blocks (3).

Insert top and then side glazing beads ensuring that they are in correctly.

Starting from top centre, insert roll in gasket (4) without stretching it (5). Stop 150mm from corner and partly cut gasket 6mm longer than the edge of the vertical bead. Insert gasket at corner and then roll in remaining 150mm. Repeat this on the other sides. Where gasket ends meet, cut gasket 6mm longer. Insert cut ends first and complete.

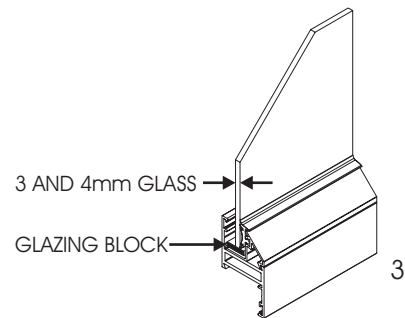
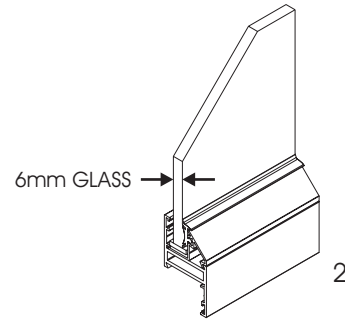

ENSURE GASKETS ARE NOT STRETCHED AT ANY STAGE

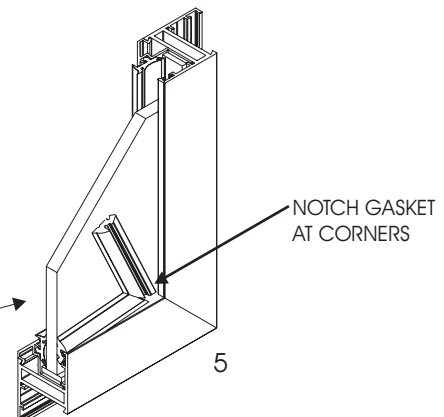
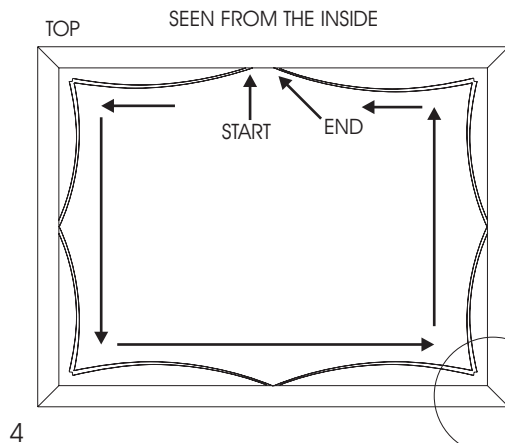

SHEERSASH 30.5 WINDOW SYSTEM GLAZING PROCEDURE CONTINUED



GLAZING

1. SELECTION OF GLAZING METHODS

1.1 SETTING AND LOCATION BLOCKS

Glass-to-metal contact must be avoided at all times by using setting and location blocks having a hardness of 50° to 90° shore A durometer. Use only blocks made of Neoprene, EPDM, Silicone or other elastomeric material.

Setting blocks are to have a minimum thickness of 3mm and must be at least 27mm in length per square metre of glass area.

In the event of laminated glass and/or sealed insulated glass units drainage is to be provided to prevent the glass edge to be submerged. Two or more 7mm diameter holes or 5mm x 9mm slotted holes, or larger, are to be equally spaced in the sill section of sash or frame to allow for such ventilation/drainage.

The position of the setting and location blocks is illustrated in Figure 2.

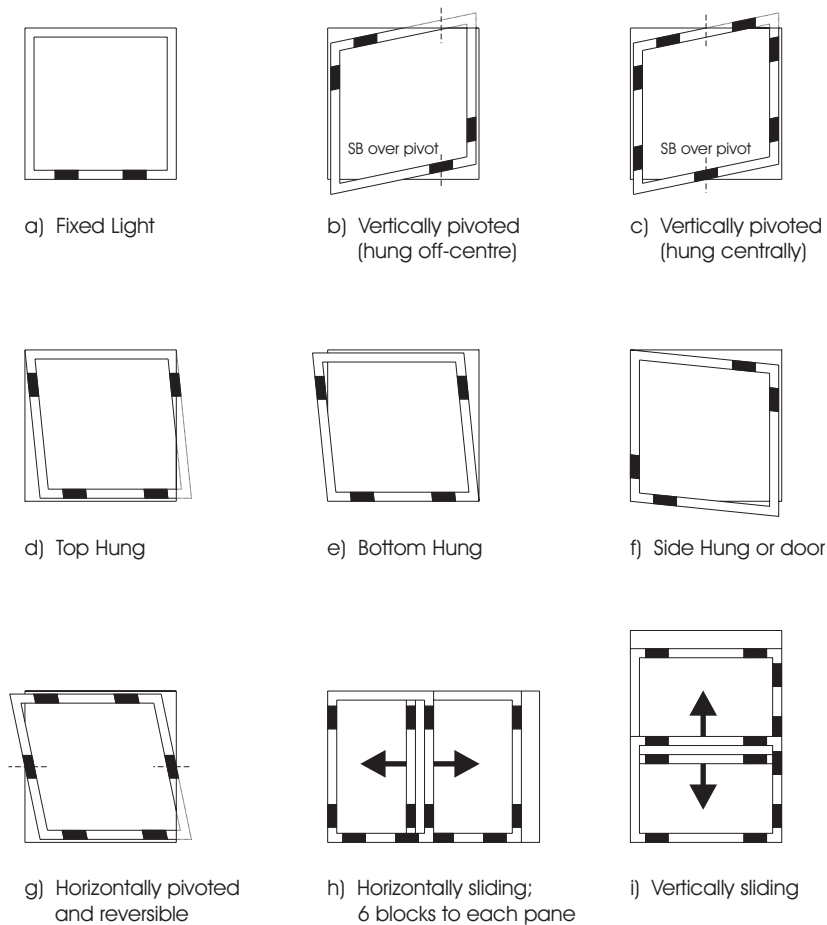
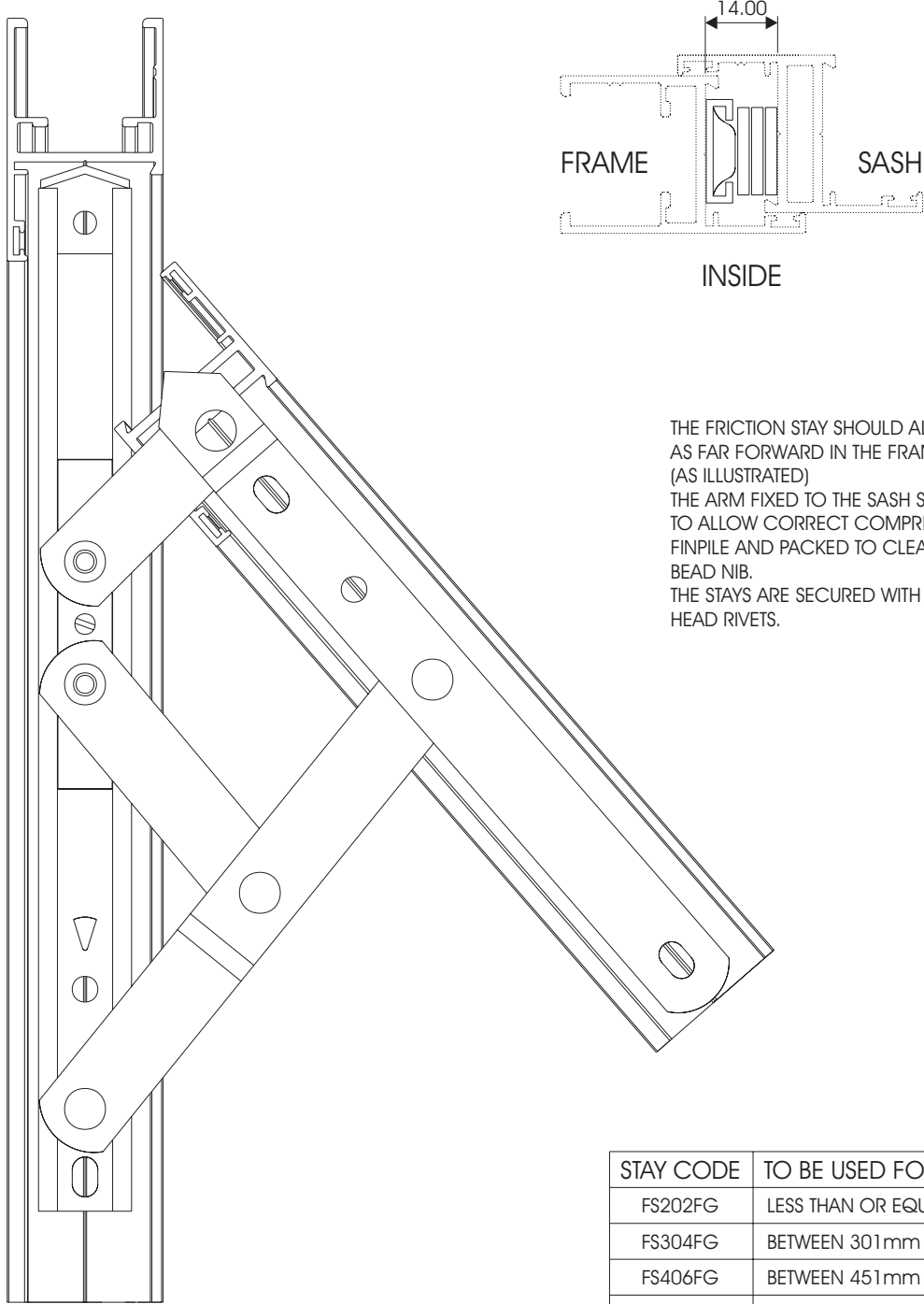

FIGURE 2 - POSITION OF SETTING AND LOCATION BLOCKS

SHEERSASH 30.5 WINDOW SYSTEM FRICTION STAY ASSEMBLY DETAIL



THE FRICTION STAY SHOULD ALWAYS BE FITTED AS FAR FORWARD IN THE FRAME AS POSSIBLE. (AS ILLUSTRATED)
 THE ARM FIXED TO THE SASH SHOULD BE FITTED TO ALLOW CORRECT COMPRESSION OF THE FINPILE AND PACKED TO CLEAR GLAZING BEAD NIB.
 THE STAYS ARE SECURED WITH 4.8 x 10 DOME HEAD RIVETS.

STAY CODE	TO BE USED FOR SASH SIZE
FS202FG	LESS THAN OR EQUAL TO 300mm
FS304FG	BETWEEN 301mm AND 450mm
FS406FG	BETWEEN 451mm AND 600mm
FS508FG	BETWEEN 601mm AND 750mm
FS600FG	GREATER THAN 750mm

SHEERSASH 30.5 WINDOW SYSTEM HANDLE ASSEMBLY DETAIL

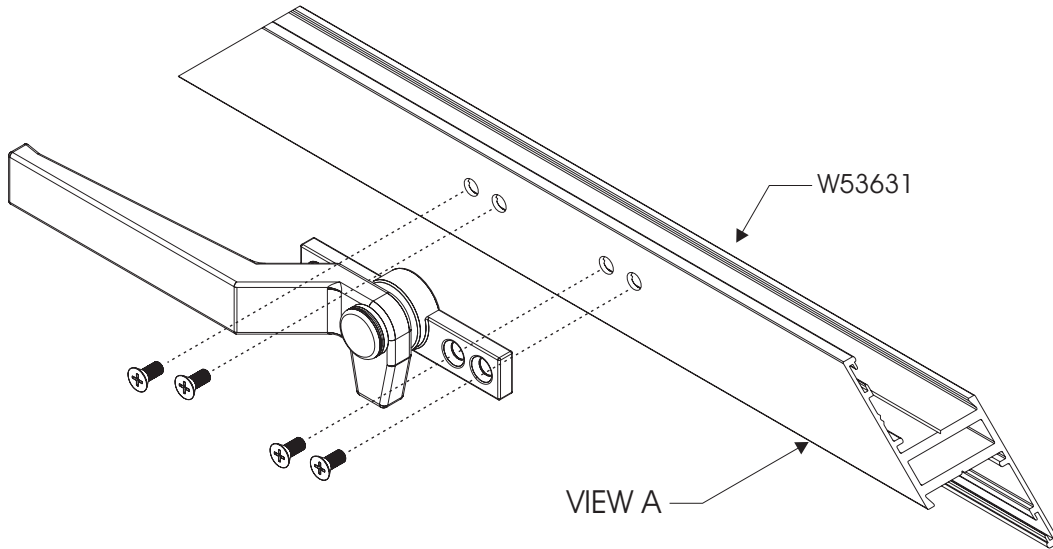

NO 8 x 10 COUNTERSUNK SELF-TAPPING
FLAT END SCREWS

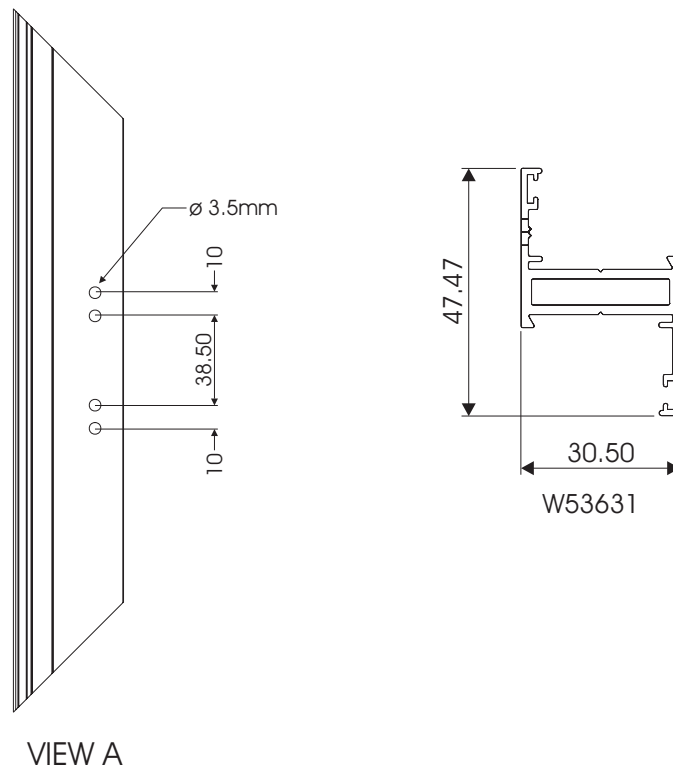

Disclaimer: The right to make alterations is reserved
© 2010 Sheerline, All Rights Reserved

SHEERSASH 30.5 WINDOW SYSTEM FIXING LUG PREPARATION DETAIL

